

TWO POST LIFT

PRO-SERIES
Equipment
 888-736-5094
www.ProSeriesEquipment.com

PSEOH-10SL

SPECIFICATIONS

Model		PSEOH-10SL
Lifting Capacity		10,000lbs
Lifting Time		45S-65S
Lifting Height	A	74 3/4"-78 3/4"(1900-2000mm)
Overall Height	B	139 3/4"-8 5/32"(3550+207mm)
Overall Width	C	141 5/16"(3590mm)
Drive-Thru Clearance	D	107 5/16"(2728mm)
Front arms	E	24 3/16"-45 1/4"(615-1150mm)
Rear arms	F	35 1/16"-54 11/16"(890-1390mm)
Width Between Columns	G	118 1/8"(3000mm)
Minimum Pad Height	H	3 3/4"-6 1/4"(95-160mm)
Motor		2.2kW
Electricity supply		220volt

TWO POST
 ONE SIDE
 MANUAL RELEASE

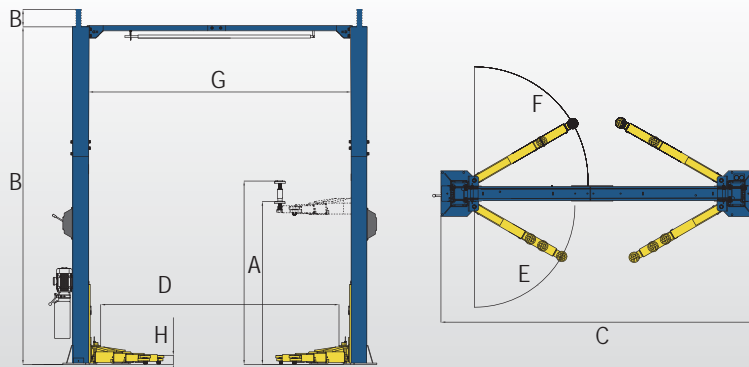

Pro Series Equipment - Distributed By

DWI Power Systems - www.DWIProSeries.com
 Home of Pro Series Equipment
 130 Commerce Drive
 Franklin, IN 46131
 317-736-5094



TWO-POST
ONE SIDE
MANUAL RELEASE

- ✓ Clear floor design for easy movement of maintenance equipment under the raised vehicle.
- ✓ Cylinder straight top device, run more smoothly.
- ✓ Durable cylinders in each column with anti-surge valves.
- ✓ With vehicle roof protection. The power system switches off when vehicle roof touches the rubber protected overhead bar.
- ✓ Pre-fixed hydraulic pressure prevents overloading operation.
- ✓ 3-stage short arm and 2-stage long arm.



FEATURES



Single Hand-Held Release



Easier for making both sides work synchronously



Strong Carriage and Arm Structure



3-Stage Short Arm And 2-Stage Long Arm

TWO POST LIFT

- 5/3/2 WARRANTY POLICY
- 5 years for lift structure
- 3 years for hydraulic components
- 2 years for electrical parts