

TWO INDEPENDENT COLUMNS

PRO-SERIES
Equipment
888-736-5094
www.ProSeriesEquipment.com

PSECF-11EV

SPECIFICATIONS

Model	PSECF-11EV
Lifting capacity	11,000lbs
Max lifting height	78 3/4"(2000mm)
Min height	4 5/16"(110mm)
Lifting time	Approx. 25S
Motor	3.5kWx2
Drive-through width	114 11/64"-129 59/64"(2900-3300mm)
Overall height	114 5/8"(2912mm)
Electricity supply	220V/1PH/60HZ

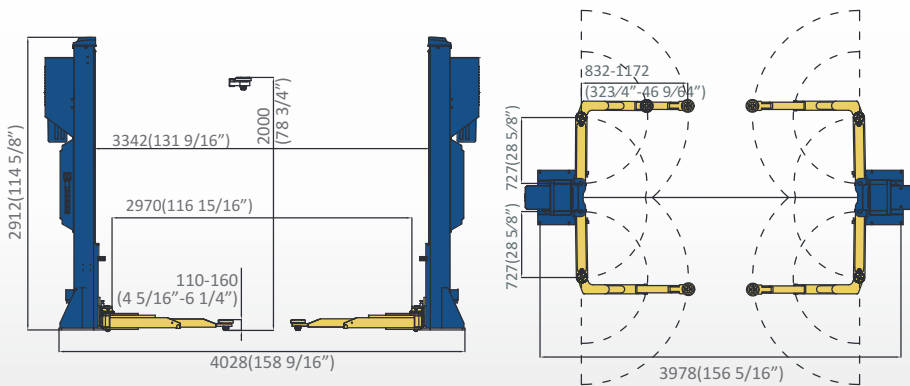

TWO INDEPENDENT COLUMNS
INDEPENDENT COLUMNS
NO STEEL ROPES



Pro Series Equipment - Distributed By

DWI Power Systems - www.DWIProSeries.com
Home of Pro Series Equipment
130 Commerce Drive
Franklin, IN 46131
317-736-5094



TWO INDEPENDENT COLUMNS
INDEPENDENT COLUMNS
NO STEEL ROPES

- ✓ Each column has an independent control and hydraulic power unit which provides adequate power for fast lifting and make it able to control at either side.
- ✓ HMI screen for setting networks and displaying crucial parameters.
- ✓ No interconnected ropes, hoses or wires between the two posts provides a free and unobstructed working space.
- ✓ Synchronization is automatically achieved by wireless communication technology and deviation is only allowed within a safe range.
- ✓ Pure hydraulic drive, no lifting elements like lead screws, chains or wire ropes.
- ✓ Less maintenance cost in the long run.
- ✓ Less installation work and more adaptable to various spaces.
- ✓ More flexible three stage arms.
- ✓ Detecting device to identify the engagement and disengagement of the mechanical locking unit.
- ✓ Type-C arms to pick up from the Smart to the long wheelbase MPVs or Vans.



FEATURES



Intelligent Control System

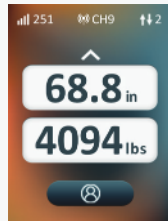

HMI Screen
(Optional weight indicator)

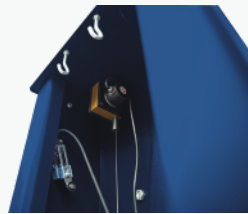

Height Limit Switch and Displacement Sensor



C Arm

TWO POST LIFT

5/3/2 WARRANTY POLICY

5 years for lift structure

3 years for hydraulic components

2 years for electrical parts