

**PRO-SERIES**

888-736-5094 **Equipment**  
www.ProSeriesEquipment.com

ALL FOR AUTO

IETEM NO: PSE-WBH448

**USER MANUAL**



FOLLOW THE INSTRUCTIONS CAREFULLY TO GRANT THE MACHINE A CORRECT FUNCTION AND LONG SERVICE LIFE.

KEEP THE MANUAL NEAR THE MACHINE ALL TIME AND MAKE SURE ALL USERS HAVE READ THIS.

# 1、 Summary of the balancing machine

## 1.1、 Characteristic of wheel balancer:

- ① Advanced computer processing system, original design concept, make sure the balancing machine is fast, a high precision, high intelligence and high stability.
- ② Perfect wheel data input function, it is suitable for the unit system transformation of different countries and regions, convenient and fast.
- ③ Standard calibration function, it is convenient for users to eliminate the measurement error of equipment caused by various reasons, to make sure the accuracy of the machine.
- ④ Multiple balance options, suitable for all types of wheel balancing.

## 1.2、 Main technical parameters

- ① Power supply: 110V-380V (option)
- ② Machine power: 550W
- ③ Balancing speed: car 180r/min bus (truck) 90r/min
- ④ Max wheel weight: car  $\leq 65\text{Kg}$  bus (truck)  $\leq 200\text{Kg}$
- ⑤ Running noise:  $\leq 69\text{db}$
- ⑥ Range of measurement:
  - Rim diameter: 10''-28'' (25.4cm-71.12cm)
  - Rim width: 1.5''-20'' (3.81cm-50.8cm)
- ⑦ Working temperature :  $0^{\circ}\text{C}-50^{\circ}\text{C}$  , relative humidity  $\leq 80\%$  , non-condensing

## 1.3、 Operating principle

The CPU can only run the balancing operation when it receives the normal information from each unit. In the balance process, the CPU comprehensively analyzes the unevenness detected by the piezoelectric sensor and the Angle signal of the counting sensor, calculates the unbalance value, which is displayed by the LED, realizes man-machine dialogue through the keyboard, and achieves the tire balance.

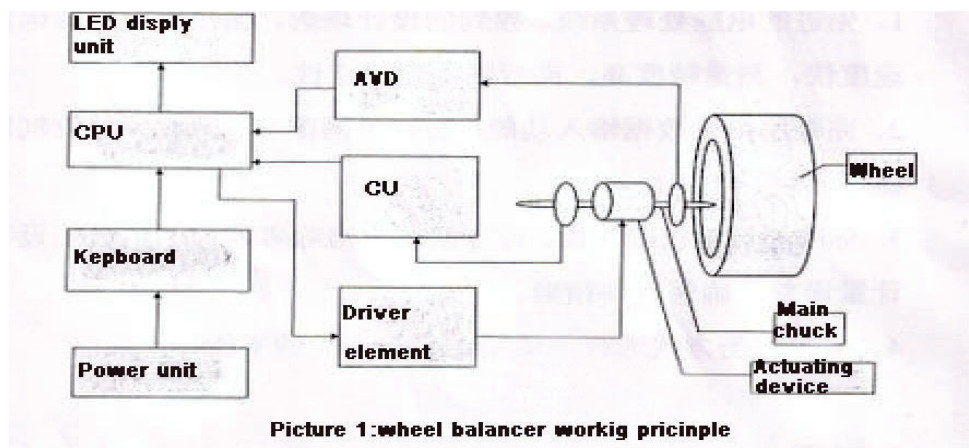

## 2、Balancing machine installation guide

2.1、Open the package, remove the connecting screw between the balancer and the bottom bracket of the packing case, lift-off balancing machine, place it on a flat, solid ground, there should be more than 800mm space around the balancing machine for the operating convenience.

2.2、Electrical connection (Must comply with the requirements of the country and region)

**Operated by a professional electrician, the body box must be grounded.**

2.3、Before connecting the main shaft of the balancing machine with the screw, wipe the connection between the spindle head and the screw first, then tighten it with a wrench.

## 3、Balancing machine operation guide

3.1、Main structure and function

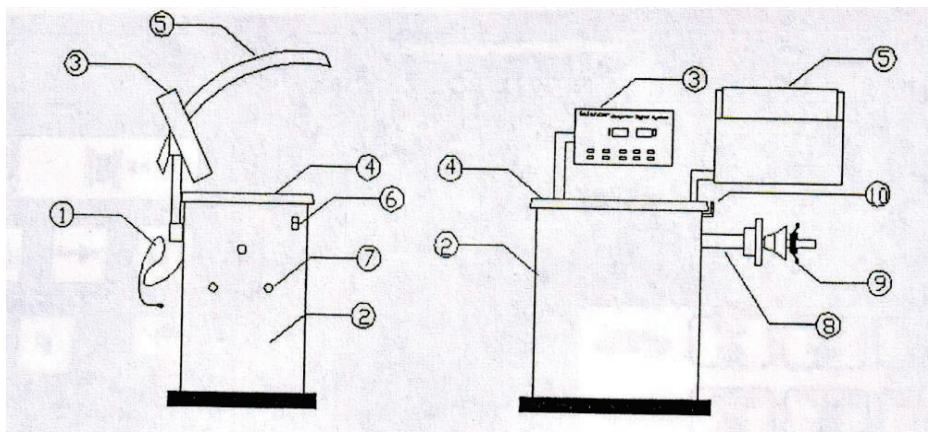

- 1、 Power plug      2、 Body box      3、 Control panel
- 4、 Weights box    5、 Protective cover    6、 Power switch
- 7、 Tooling shank    8、 Balancing shaft    9、 Quick nut
- 10、 Meter

### 3.2、 Display and control panel

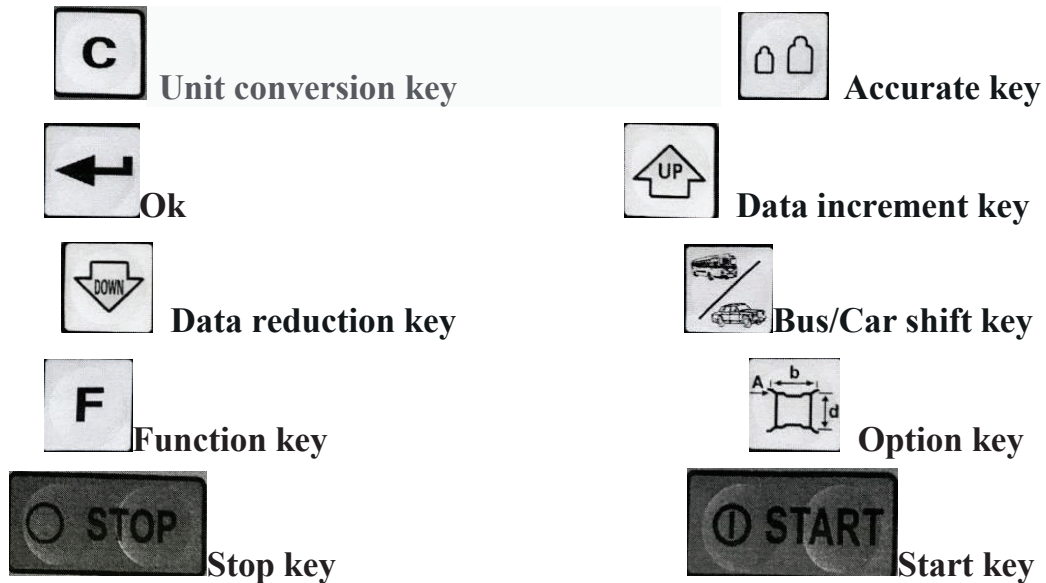
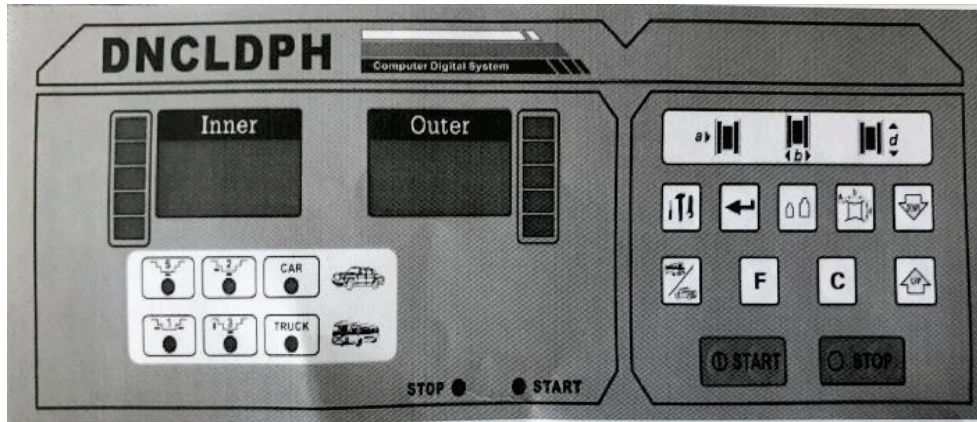

### 3.3、 Instructions:

#### ① Starting:

Turn on the power switch and start self-check inside the balancing machine. The default measurement option after self-inspection is standard dynamic balance of truck state. (It takes more than 5 seconds to restart the machine) .







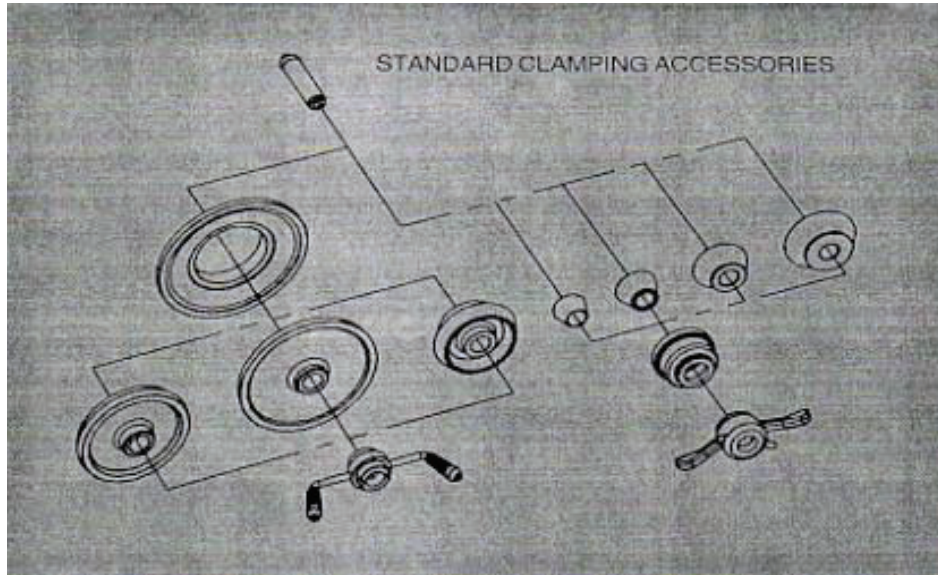

#### ② Wheel installation

When the wheel is installed, different clamps are selected according to the tire size, as shown in the picture:





③ Wheel data input:

- (1) Press  key and choose a, pull the ruler to the inside of the rim and install the equalizer, according to the number, press  or  key, type the actual value. This machine defaults to the common value mm.
- (2) Then press  key and select input rim width data b, measure the width of two rims with the width gauge in the accessories, press  or  key, input the width data of the caliper. This machine defaults to British Inch.
- (3) Then press  key and select data d to enter the tire diameter, Check the tire marking to confirm rim diameter and then press  or  key, input the rim diameter date. This machine defaults to British inch.

3.4、 Select and change the Unit

Press C key can change Gram & Ounce .

3.5、 Some examples about balancing

After boot, the spindle is fitted with tires to select the appropriate cone, and the quick release nut is locked.

Input a、 b、 d three datas .

For instance : as picture

- Press **START** key ,7 seconds later ,automatic brake shows as picture:  
**145** is add lead lump value inside tire.  
**115** is add lead lump value outside tire .



- Rotate wheel to make inside indicator lamp be on and vertical over the main shaft, strike 145g lead lump on wheel steel (as picture)



- Then rotate wheel to make outside indicator lamp be on and vertical over the main shaft, take away 115g lead lump from wheel steel (as picture)



- At this time outside indicator also indicates 0, balance is over, unload the tyre. If you test the tyre again, you needn't switch off power.



### 3.6、 Options for mode of balancing (Press F key to select)

- Static balance: revision is adopted when balance lump can't be added on wheels both sides of rim.



- ALU1 —Balance the light-alloy rim, adopt a way of adhering balance lump on the two shoulders in the rim.

$$A1 = A + \frac{3}{4} \text{ inch} \quad A2 = A + b - \frac{3}{4} \text{ inch}$$



- ALU2 — Balance the light-alloy rim, adopt a way of gluing balance lump hidden inside.

$A1 = A + 3/4$  inch

$A2 =$  point 0 to the outer distance of flange –  $1/2$  inch





- ALU3 — Inner circle clips balance lump, outside adhere to balance lump .

$A1 = A$   $A2 =$  point 0 to the outer distance of flange -  $1/2$  inch



#### 4、 Self - calibration















( Car and truck tires need to be corrected separately )

A wheel with sufficient air on the spindle, input A、b、d three datas, at the same time press  and  keys, A few seconds later, display window show **CAL** **CAL** ,press  key show **Add** **0** , press **START** key ,after the machine stops running show **Add** **100** , push the wheel , just above the outside position , ( When the leaded position indicator lights are all on ) , add 100g standard lead lump ,then press **START** key , after the machine stops running show **100** **Add** ,Remove the 100g rectified lead block from the outside ,directly above the inner side position ( When the leaded position indicator lights are all on ) ,then press **START** key , after the machine stops running show **END** **CAL** ,self calibration is ending .

**Tip: When going self calibration , Make sure that the wheel is required to be plentiful air , Remove dirt or impurities from the tires, The balancer must be stable**







## 5、 Function setting

Press  key in 5 seconds , access to the following feature settings:

- p— Protection cover setting . Press  key , then press  key set, Setting protection function ON、 OFF, then press  key confirm .
- b1p On the top operation, then press  key , press  confirm to set B1p。 electric whistle ON、 OFF, press  key confirm .
- APP On the top operation, press  key ,press  key confirm to set APP.Press  key,set 1g or 5g, press  key confirm .
- P.C Protection cover control function setting.on the top operation, press  key,press  key confirm to set P.C.press  key to set ON/OFF, press  key confirm .Press Stop key to exit function settings

**Tip: Base on the requirements of different countries and regions, users can set up their own protection cover function**

## 6、 Balancing machine self-testing function

Press  and  key , A few seconds later, display window show **CAL** **CAL**, press  key , A few seconds later, display window show **ES**  .Then press  key, show **POS** **XXX** .To push the wheel forward or backward, from **0** to **127** repeated change, it shows that the photoelectric sensor works normally.Then press  key, show **STA** **XXX** , To press the balance shaft by hand, Digital change, It shows that the vertical sensor assembly is normal. Then press  key, Show **DYN** **XXX** , To press the balance shaft by hand, Digital change, It shows that the horizontal sensor assembly is normal. Press Stop key to end self-testing.



## 7、 Common failure codes and solutions

Err—1— No counting signal, replace the computer and photo electricity board

Err—2— The test speed is not enough, the spindle does not rotate the wheel

Err—3— Big Measurement error, cannot calculate, replace the wheel and test again.

Err—4— Detection of reverse, replace the photoelectric board or computer board、 three phase electric phase modulation

Err—5— Choose the function of protective cover correctly













Err—6— The code is not set

Err—7— Incorrect correction, re-calibration

Err—8— Uninitialized, need correction

### Prompt:

1. When using a balancing machine without a tire protective cover, press the start key, if the display window shows -ERR-5-, indicates that the balancing machine is in a self-locking state, unlock it before working

normally. Method are as follows: Press  key for 5 seconds , display   , press  , display   , press  or  key, display   , then press  unlock function , press  to eliminate. The balancer will lock itself immediately if it is subject to external interference (such as electromagnetic interference), achieve self – protection.

2. No error display during measurement, such as display 0 0(0.00 0.00), Re-calibrate can be solve this problem.

3. If any key does not work (the machine is not working).Turn off the power and restart it.

# EXPLODED DRAWINGS

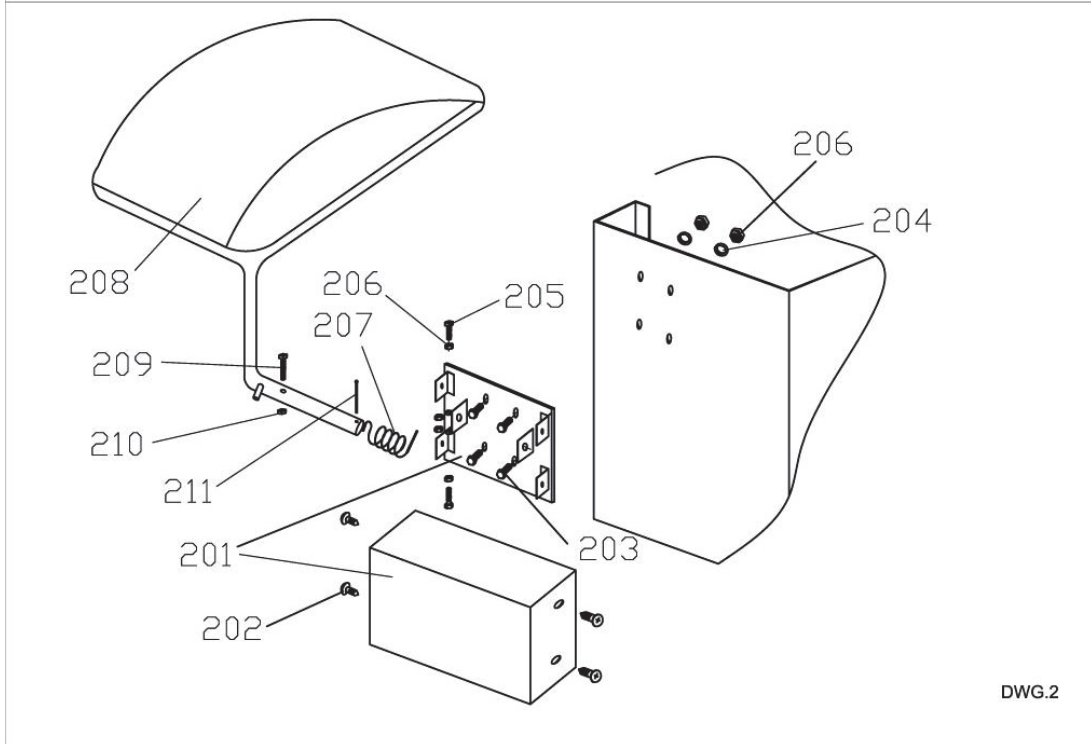
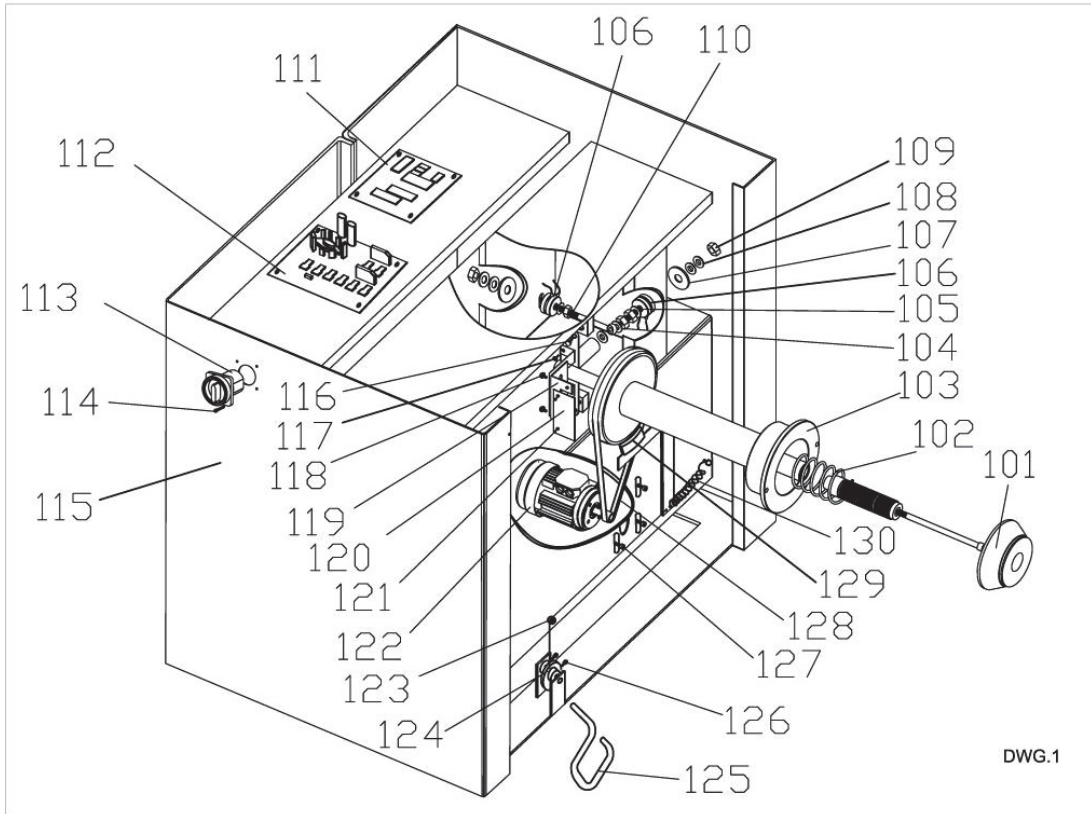

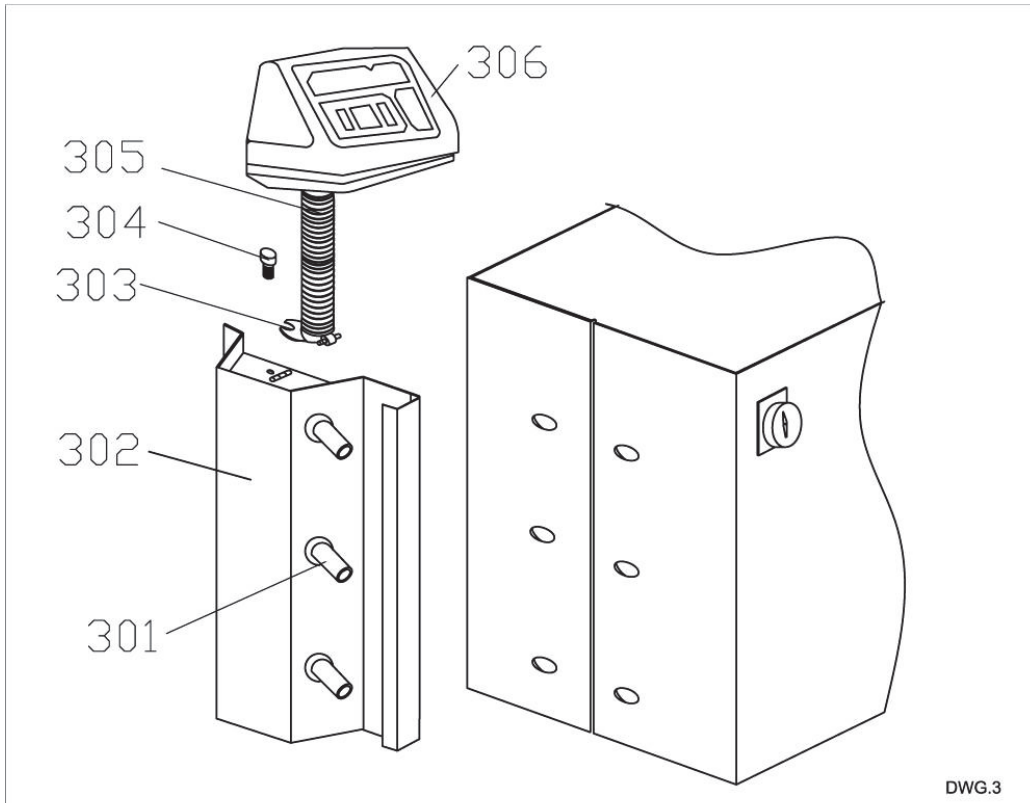

DWG.3

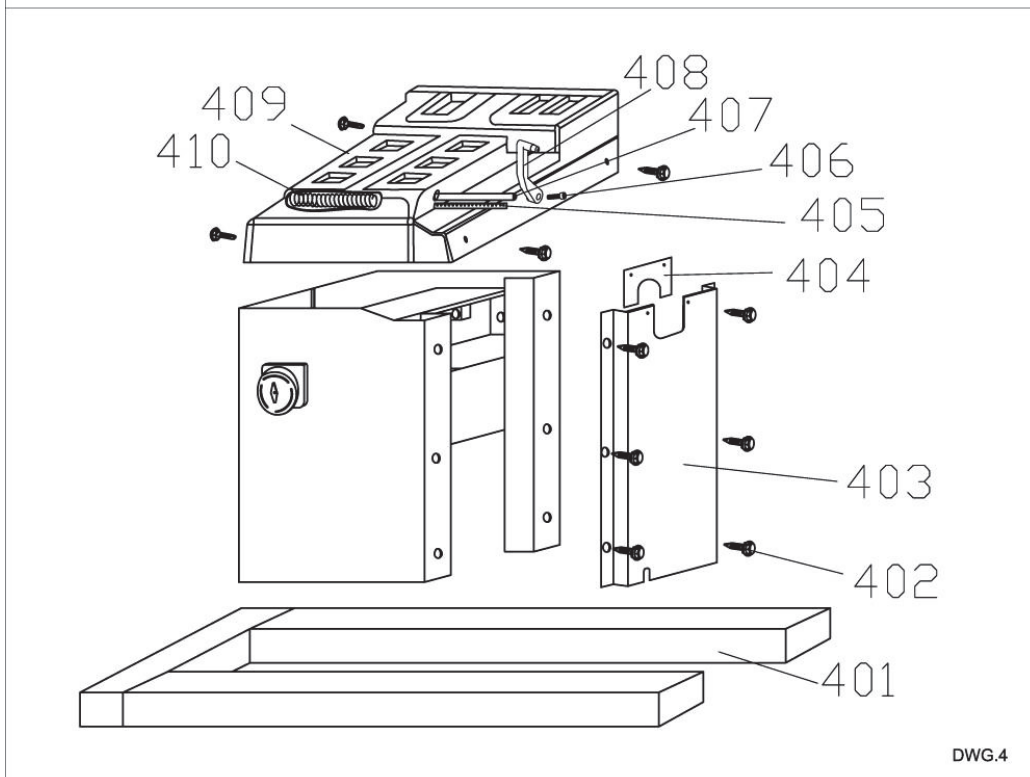

DWG.4

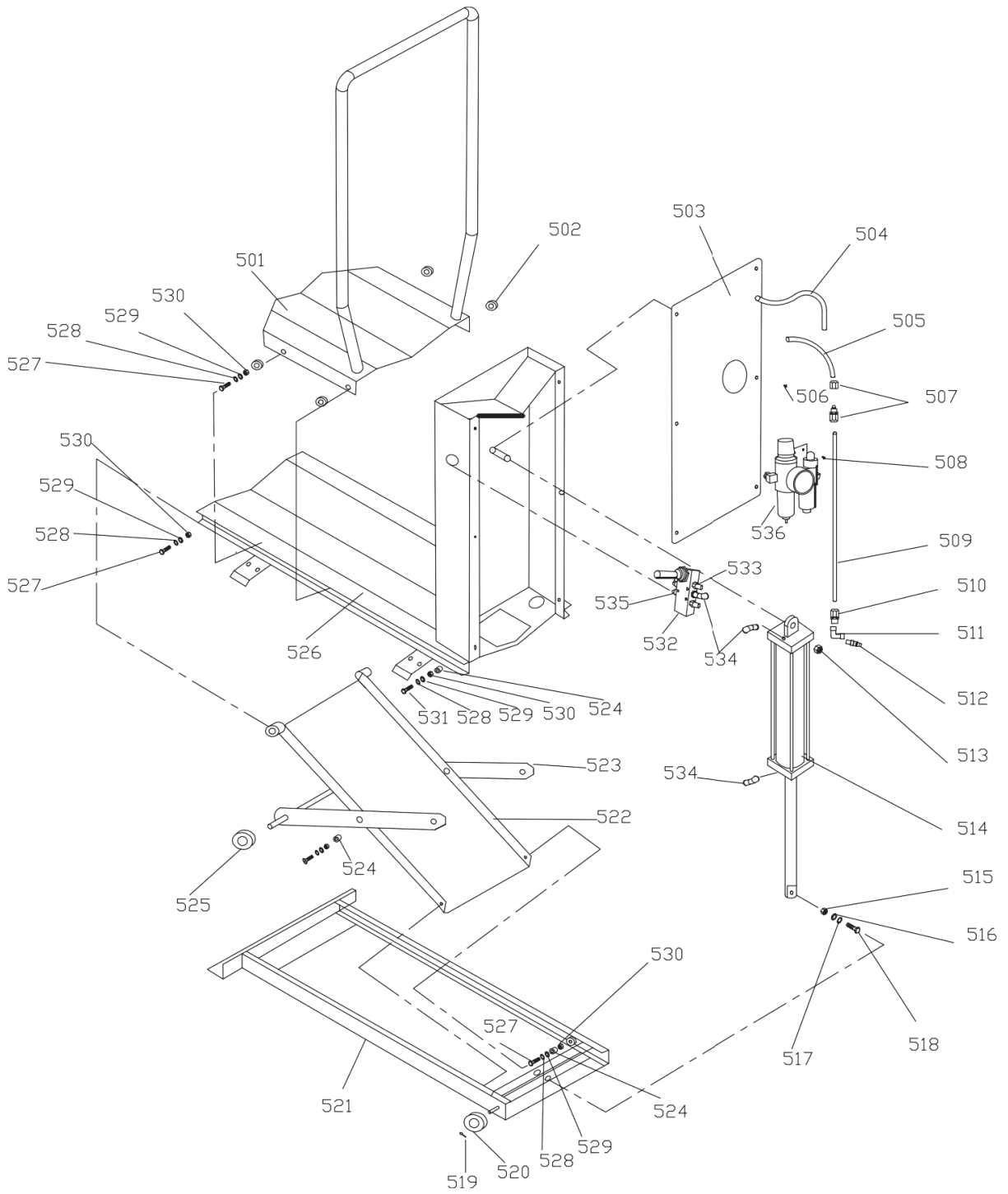



## 8. SPARE PART LIST

NO.	Code	Qty.	Description	NO.	Code	Qty.	Description
101		4	Set of cones	401		1	Pedestal
102		1	Spring	402		10	Screw M6*35
103		1	Bearing	403		1	Big plate
104		4	Washer $\phi$ 10	404		1	Small plate
105		1	Through bolt(H)	405		1	Graduated strip
106		2	Sensor assembly	406		1	Screw M6*16
107		2	Washer	407		1	Rim gauge
108	GB/T1972	4	Butterfly washer $\phi$ 10	408		1	Handle bar
109		5	Nut M10	409		1	Head with tools-tray
110		1	Through bolt(V)	410		1	Spring
111		1	Computer board				
112		1	Power board	501			Pallet
113		1	Switch	502			Bearing
114		4	Screw M4*30	503			Backside board
115		1	Body	504			Soft hose
116		4	Screw M10*25	505			Soft hose
117		2	Screw M4*10	506			Fast-break
118		2	Screw M4/8	507			Hose connetor
119		1	Support	508			M5X10 Screw
120		1	Photoelectricity sensor	509			Copper pipe
121		2	Screw M3*8	510			Hose connetor
122		1	Motor	511			Elbow
123		1	Idler pulley	512			Quick connetor
124		1	Rotate pulley	513			M12 Nut
125		1	pedal	514			Cylinder assembly
126		2	Screw M6*16	515			M12 Nut
127		4	Screw M6*20	516			$\phi$ 12 Washer
128		1	Belt	517			$\phi$ 12 Washer
129		1	Brake patch	518			M12X45 Screw
130		1	Spring	519			Open lock
				520			Roller
201		1	Cover	521			Base plate
202		4	Screw M4*8	522			Shear arm 1
203		4	Screw M8*16	523			Shear arm 2
204		4	Washer $\phi$ 8	524			Bushing
205		2	Screw M8*25	525			Nylon wheel
206		8	Nut M8	526			Lifting platform
207		1	Spring	527			M12X25 Screw
208		1	Plastic cover	528			$\phi$ 10 Washer
209		1	Screw M10*55	529			$\phi$ 10 Flat
210		1	Nut M10	530			M10 Nut
211		1	Bolt	531			M10X30 Screw
				532			Air switch
301		1	Hang pin	533			Muffler
302		1	Box	534			Bend fast plug
303		1	Support	535			Fast plug
304		1	Screw M10*16	536			Oil-water separator
305		1	Nylon knot				
306		1	Plastic cover				