

IITEM NO: PSE-TC980

USER MANUAL



FOLLOW THE INSTRUCTIONS CAREFULLY TO GRANT THE MACHINE A CORRECT FUNCTION AND LONG SERVICE LIFE.

KEEP THE MANUAL NEAR THE MACHINE ALL TIME AND MAKE SURE ALL USERS HAVE READ THIS.



WARNING

- This manual is a necessary part of the product. Please read carefully.
- Keep the manual for later use when maintaining the machine.
- This machine can only be used for the designated purposes. Never use it for any other purpose.
- The manufacturer is not responsible for the damage incurred by improper use or use other than the intended purpose.

Precautions

- The equipment can only be operated by qualified personnel with special training. Modification to any components or parts, or use the machine for other purpose without either obtaining the agreement from the producer, or observing the requirement of the instructions may lead to direct or indirect damage to the equipment.
- The equipment should be installed on the stable ground.
- Keep the back panel 0.5M away from the wall for good ventilation. Enough room should be left on both sides for convenient operation.
- Do not put the equipment a place with high temperature or moisture, or near the heating system, water tap, air-humidifier or chimney.
- Do not put the equipment near the window with sunlight. Protect the unit with a curtain or shield if necessary.
- Avoid lots of dust, ammonia, alcohol, thinner or spraying binder.
- People who are no operating the machines should be kept away when it is used.
- Use appropriate equipment and tools, protective and safety equipment, including eyeglasses, earplugs and working boots.
- Pay special attention to the marks on the machine.
- Do not touch or approach the moving parts by hand during operating.
- Do not remove the safety device or keep it from working properly.
- Before moving the tire changer, contact maintenance personnel.

Contents

Safety Precautions	1
1. General Information	3
1.1 Usage.....	3
1.2 Features.....	3
1.3 Specifications.....	3
1.4 Applicable Range.....	3
1.5 Working Conditions.....	3
1.6 Description of Safety Signs.....	4
1.7 Position of Safety Signs.....	4
2. Main Structure	5
3. Installation and adjusting	6
3.1 Unpacking.....	6
3.2 Location.....	6
3.3 Installation.....	7
3.4 Power and Air Connections and Regulator.....	9
4. Operation	10
4.1 Principles.....	10
4.2 Demounting Tire.....	10
4.3 Mounting Tire.....	13
4.4 Inflating Tire.....	14
5. Trouble Shooting	15
6. Maintenance	16
7. Storing and Scrapping	16
7.1 Storing.....	16
7.2 Scrapping.....	16
8. Spare Parts List	17
9. Exploded Drawings	21
9.1 Column Assembly.....	21
9.2 Turntable Assembly.....	22
9.3 Gearbox & Motor Assembly.....	23
9.4 Body Assembly.....	24
9.5 Pedal Assembly.....	25
9.6 Bead Breaker Cylinder & Breaker Arm Assembly.....	26
9.7 Quick inflating system (optional).....	27
Appendix 1: Electrical Diagram	28
Appendix 2: Air Passage Diagram	29
Appendix 3: Drawing of installation for small package	30

1. General Information

1.1 Usage

The Machine is used for demounting, mounting and inflating tires of small vehicles. It features simple operation and high reliability. In addition, it can also be a great help in car repair garage and tire dealers.

1.2 Features

- The equipment can be used for different purposes of demounting, mounting and inflating tires.
- The steel mount/demount is cast from excellent alloy material with special shape and durable performance. The optional plastic mount/demount head with the equipment is made from special engineering plastic that has enough intensity and not damage the tire and rim.
- The two clamping cylinder ensures accurate central alignment, so that the tires can be held tightly.
- The layout of the pedals gives convenience to the operating personnel.
- The distance of bead breaker is large enough for big tire.
- Tire lever and lubrication box are easy to reach.

1.3 Specifications

Dimensions

Maximum height: 2000 mm

Length: 1050 mm

Width: 1100 mm

Noise

Working noise: ≤70dB(A)

Air supply

Working pressure: 8—10 bar

Bead breaker force: 14000 N

Electric specifications

Voltage to choose:

NO.	Voltage	Power	Phase
1	AC110V/60Hz	1.1kW	single
2	AC220V/50Hz	1.1kW	single
3	AC220V/60Hz	1.1 or 0.75kw	Single/t hree
4	AC380V/50Hz	0.75kW	three
5	AC200V/50/60HZ	1.1kw	three

RPM of turntable: 6~7 n / min

1.4 Applicable Range

External Locking Rim diameter: 12"~23"

Internal Locking Rim diameter: 14"~26"

Max. wheel diameter: 45"(1140mm)

Max. rim width: 14"(355mm)

1.5 Working Conditions

Working temperature: -40℃—45℃

Transport/store temperature: -40℃—55℃

Humidity: 30—95%

1.6 Description of Safety Signs



- To prevent accidents from occurring, make sure to keep hands and other body parts away when fastening the mount/demount head or when the turntable is running.



- Be careful in the area of tilting column.



- Caution should be taken when separating the tire from rim. The bead breaker shoe will move rapidly and forcefully when the pedal is depressed. Keep body and materials away from the work area.

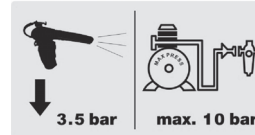

- The pressure of the compressed air should not exceed 10bar. When inflating the tire, the inflating gun pressure value should be 3.5 bar.



- High voltage power! Dangerous!

1.7 Position of Safety Signs

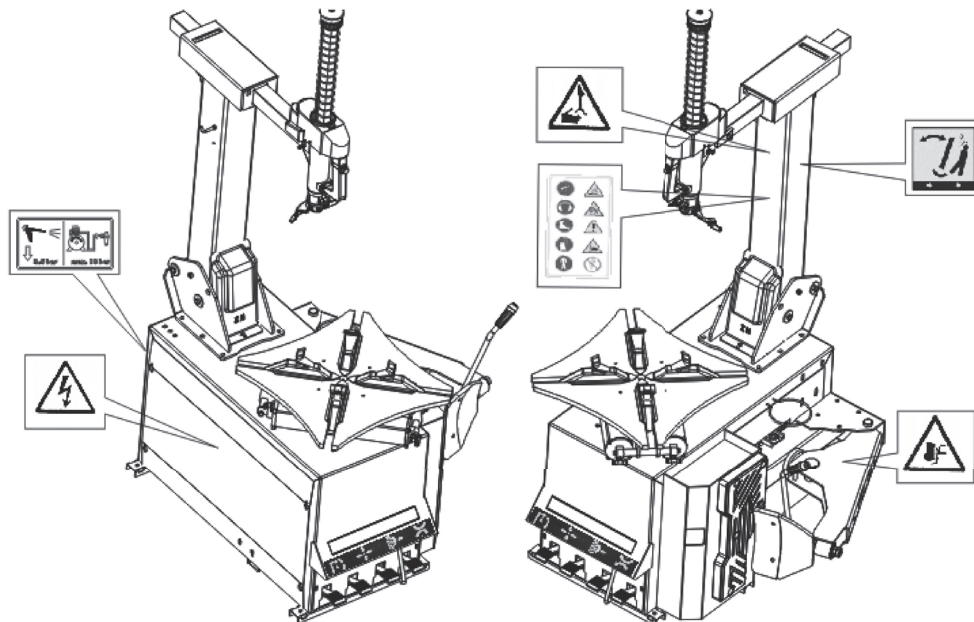

- Please change the safety signs if it gets blurred or lost.
- When one or more safety signs get lost, don't operate the machine.
- The safety signs must be kept within the sight of the operator.

2. Main Structure

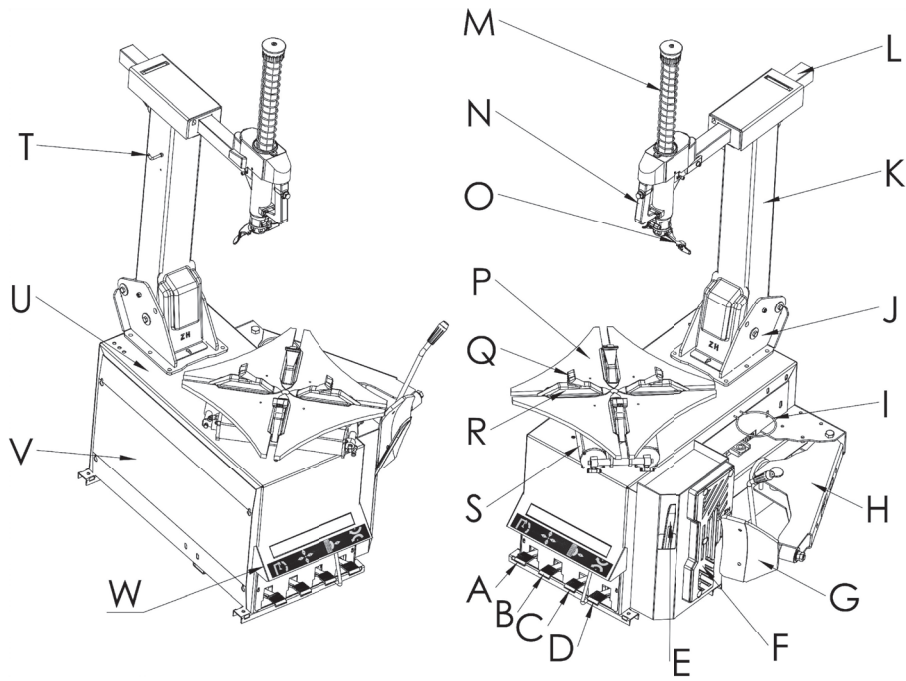

Fig.1

The main operating parts are shown in fig.1

No.	Item	No.	Item	No.	Item	No.	Item
A	Tilting pedal	G	Bead breaker shovel	M	Return spring	S	Clamping cylinder assembly
B	Jaw flex pedal	H	Bead breaker arm	N	Locking handle	T	Hanger
C	Bead breaker pedal	I	Hanger	O	Mount/demount head	U	Frame
D	Turn table control pedal	J	Column socket	P	Turntable	V	Side cover
E	Tire lever	K	Column	Q	Jaw slide	W	Pedal sign plate
F	Rubber buffer	L	Arm				

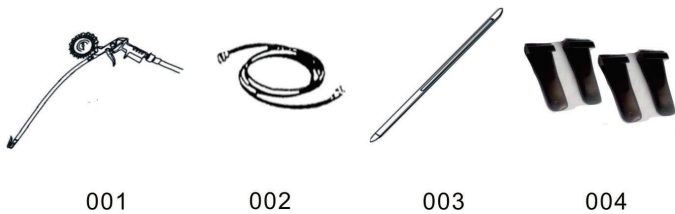

Fig.2

Accessories provided

are shown in Fig.2:

001- Inflating gun

002- Inflator tube

003- Tire lever

004- Jaw protector

3. Installation and adjusting

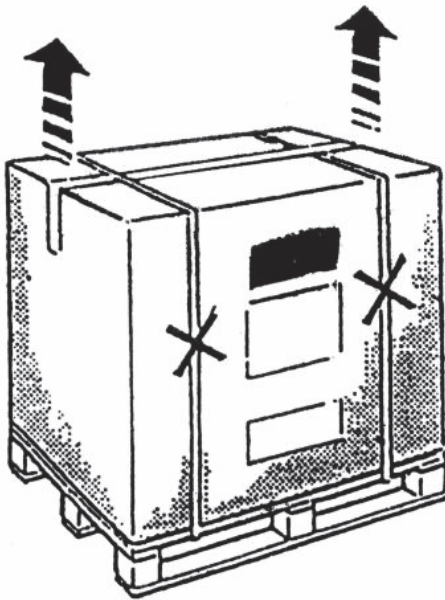

Fig.3

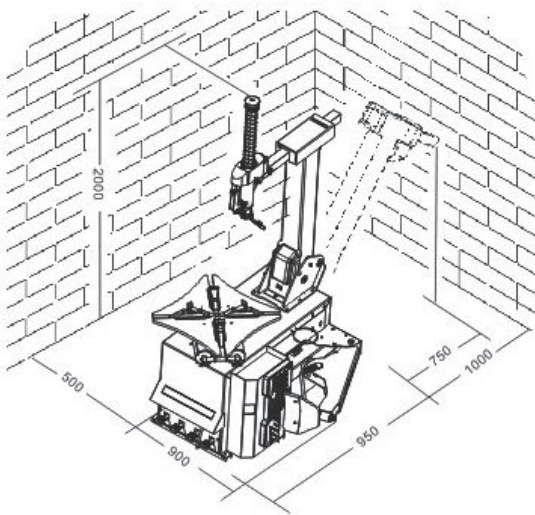

Fig.4

3.1 Unpacking

- Unpack according to the instructions on the package. Remove the packing materials and inspect the machine for possible damage or loss of accessories during transportation. In case of doubt do not use the machine and refer to professionally qualified personnel and/or to the seller.
- Keep the packing materials out of the reach of children. Handle in an appropriate way if the packing material is likely to cause pollution.
- Remove the cabinet, column, swing arm and accessory box fitted on the bottom plate and keep them in safety place.



NOTE:

A special anti-rust oil applied on the delicate parts may attract dust. Clean it when necessary.

3.2 Location

The place to install the machine should be in accordance with safety regulations:

- The machine should be installed in a place close to the main power source and compressed air system.
- Install the machine on smooth concrete ground or other ground with hard flooring. 4 sets of anchor bolts can be used to fasten the machine onto the ground to avoid vibration and noise.
- Leave enough space for the operation and maintenance of the machine. The space should be no less than 1M in front and on the two sides of the machine, 0.5M behind it so that operation on different parts shall not be hindered.
- If the machine has to be installed outdoors, a protective shelter should be built.
- Never operate the machine in a place with flammable gas.



NOTE:

For safety and proper operation, keep the machine at least 0.5M away from any wall (Fig.4)

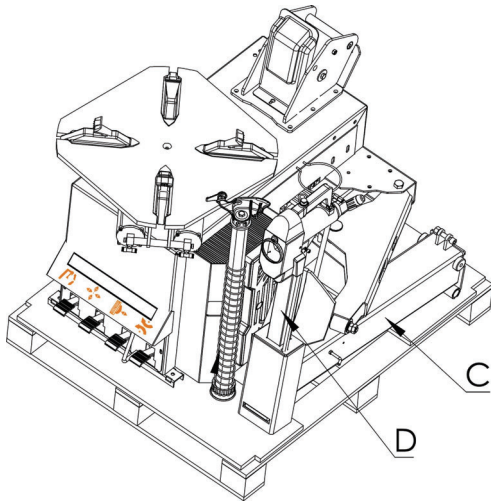

Fig.5

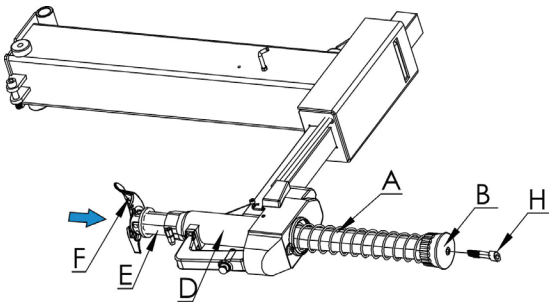

Fig.6

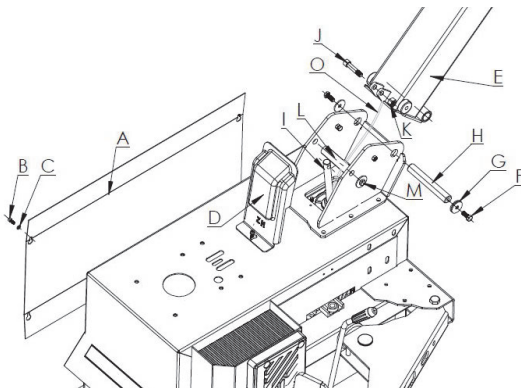

Fig.7

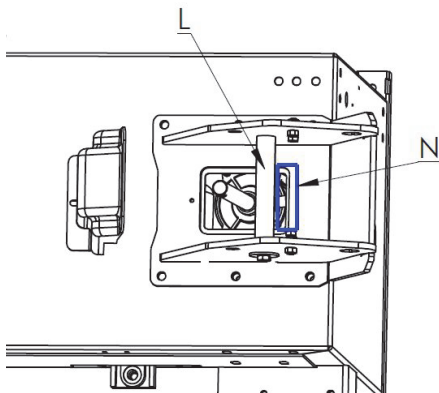

Fig.8-a

3.3 Installation

- Move the column C and arm D, put them on a soft cushion.(Fig.5)

⚠NOTE:

When you lift the column, the arm D will fall freely, be careful!

⚠NOTE:

ZH650 has two different size of packing, if it is 97x75x95mm, plz refer to Appendix 3 page30, the Drawing of installation for small package. You have to install part No. 2, 3, 4, 5, and turn around 90 degree of part No.1 as the drawing.

3.3.1 Install return spring

- Use 6mm inner hexagon spanner to take off the screw H which is inside of the plastic cover B. Take Quadrate column E out, move the spring A, then install hex column back. Put the spring A on the top of hex column and install the plastic cover B back and tighten screw. (Fig.6)

3.3.2 Install the column

- Use 6mm inner hexagon spanner to take off the screw B and washer C, then take off the side cover A and cover as fig.7.
- Lift column E as fig.7 , make pin hole of column and body in line, insert pin axis H, tighten screw F and washer G (screw M12x25) (If column can not be fixed in, loose screw M, after installation finished, tighten screw M again.) .
- Tilt column, make hose ϕ 4 M through hole O in the body N (Fig. 8).

⚠NOTE:

Before hose ϕ 4 O come through pin hole of column, make sure ϕ 4 hose O begins at the back of pin L to avoid hose damaged.

- Pull column forward slowly, when the hole in column and piston rod I in line, insert pin axis J, use washer and screw J to fix.(M12x55,fasten M12 screw K) .
- Make column straight, finish column installation.

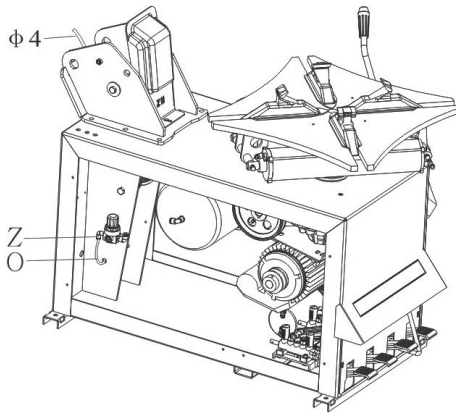

Fig. 8-b

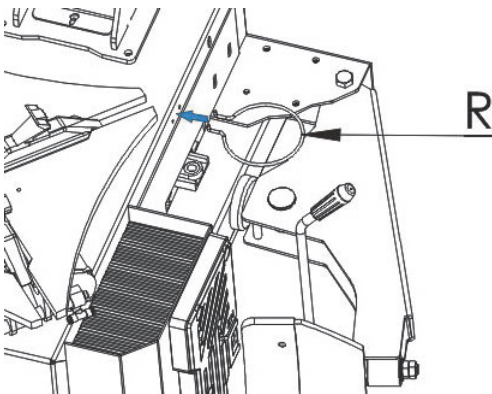

Fig. 9

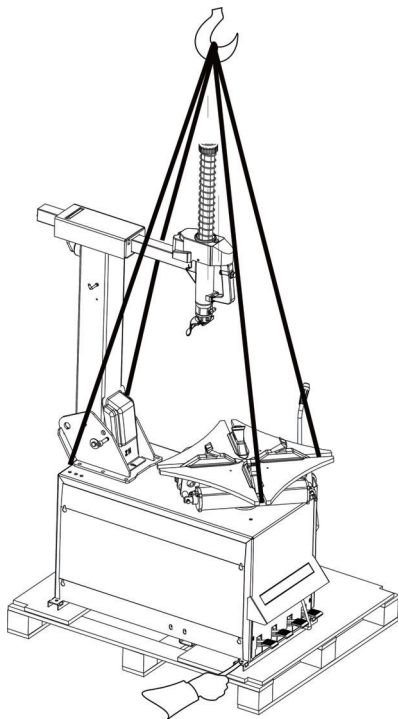

Fig. 10

- Connect hose in the column : As fig.8-b , connect $\phi 4$ hose O to regulator Z

⚠ NOTE :

When the machines come out factory, the regulator Z has already been adjusted pressure (4 bar), please do not adjust it by yourself.

3.3.3 Install Hanger

- As fig.9 Insert the two heads into two $\phi 5$ holes in the right side of column, make sure I heads, hook is upward.
- Install side cover A and cover D, fasten with screws as fig. 7 .

3.3.4 Lifting and installation

Take off 2 pieces of screws by spanner (Fig. 10). Use hoist to lift the machine, move pallet, locate the machine.

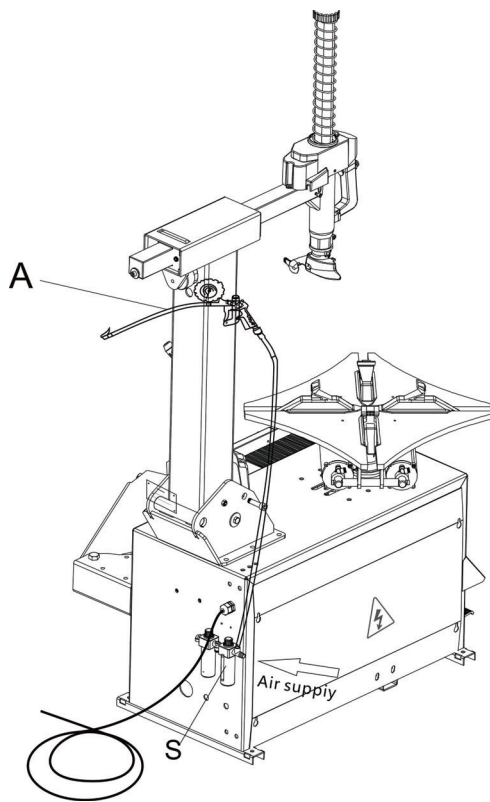

Fig.12

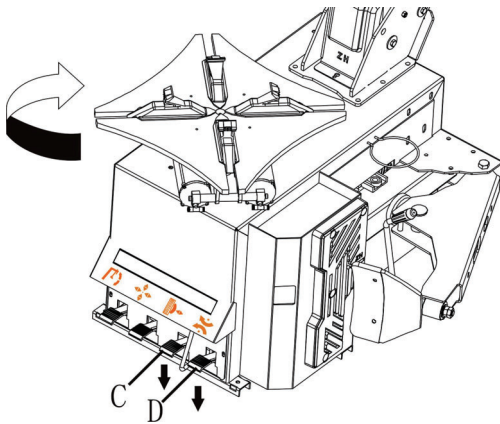

Fig.13

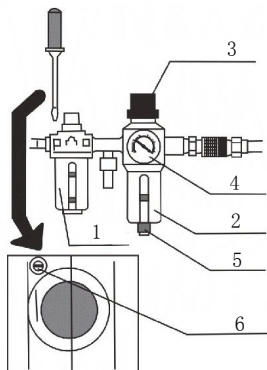

Fig.14

3.4 Power and Air Connections and Regulator

- Before installation, check if the power source and the compressed air are in accordance with the specifications on the nameplate. Any electrical connection should be done by the specially trained technician.
- The power socket should be at a place within the sight of the operator. The height should be between 24"~67".
- Grounding protection of power is needed for machine shell.
- Air connection: Connect the inflation gun A to the coupling located to the top of the air filter S (Fig.12).
- Connect the compressed air supply to the coupling located between the lubricator and the air filter S (as fig.12 , direction of arrow) .

⚠NOTE:

The tire changer is not equipped with overload protection. Please connect power according to the electric diagram included in the User's manual. Otherwise, the manufacturer will not be responsible for any accidents.

- Operation test: after power connected, press pedal D (Fig.13), turntable will turn clockwise. This test is very important.
- F.R.L. :Filter, Regulator, Lubricator Assembly(optional):
 - See Fig. 14: 1- Lubricator; 2- Filter; 3- Regulator.
 - Adjust pressure: There is a button for the regulator 3. When pulled up, the pressure can be increased or decreased by turn it clockwise or counter-clockwise (check the 4-Gauge). After adjusting the operation pressure, press the button down to lock it.
 - The Filter 2 works to filter the water and impurity in the compressed air. When water and impurities run beyond the red line, turn open the ejection valve 5 to release them.
 - The lubricator 1 is used to add a certain amount of lubricant into gas for the moving parts in the cylinder and regulator. Depress pedal C, 3~5 times, a drop of lubricant will drop into the cup in the regulator. If it doesn't happen, the adjusting screw can be adjusted.

4. Operation

NOTE:

- *Do not operate the machine before having completing training and qualified for operating the tire changer. Use appropriate equipment, tools and personal protective equipment, such as eye-glasses, ear-plugs and working boots, when operating the tire changer.*
- *Make sure that the power, air sources and the oil level in the oil cup are in accordance with the requirements.*

4.1 Principles

- To avoid damage when mounting and demounting tire, especially the alloy ones, use the special tire lever.
- For easier demounting and better protection of the tire and rim, lubricate the area between the rim and tire bead, where the bead breaker shoe goes in, with industrial lubricant or thick soap solution.
- Pay special attention to rotary direction marked on some flanges or tires.
- Fit the tire on the rim of matched size.
- Check for damages (distortions, surface damages, excessive run out, erosion or overall wear) before demounting.
- Never ignore the mounting and demounting requirements of the special wheel.
- When inflating the tire, make sure the pressure increases in an even way. Check the rim as often as possible.

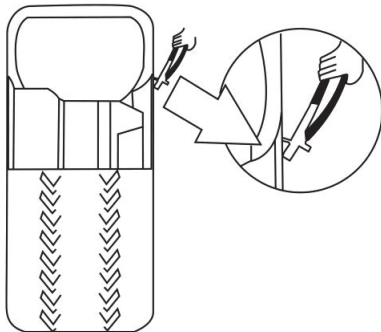

Fig.15

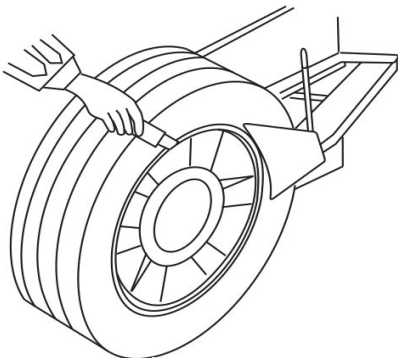

Fig.16

4.2 Demounting Tire

Preparing

- Deflate the tire thoroughly.
- Remove all the foreign substance and weights from the rim (as fig.15) .

Demounting

NOTE:

Lubricate the bead with a brush with lubricant before the shoe touches the bead. Otherwise the tire bead will be worn (Fig.16).

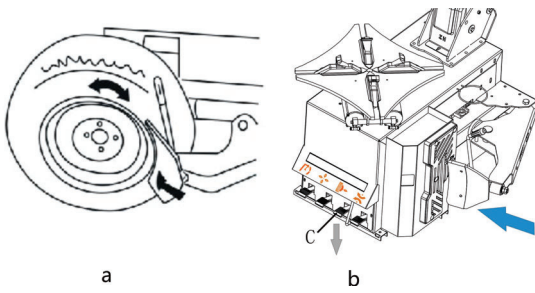

Fig.17

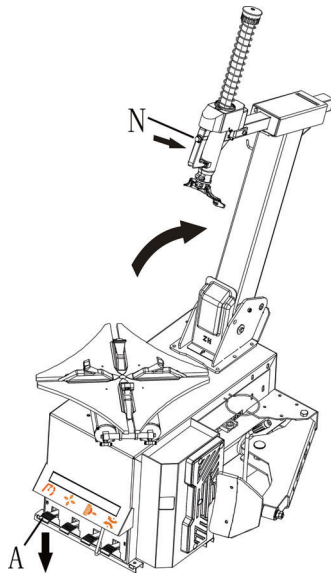

Fig.18

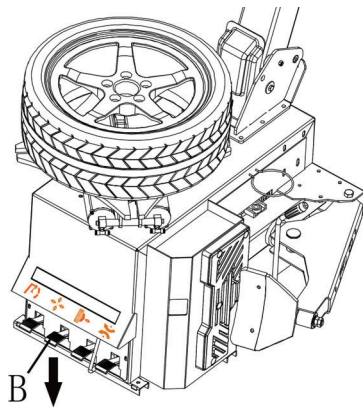

Fig.19

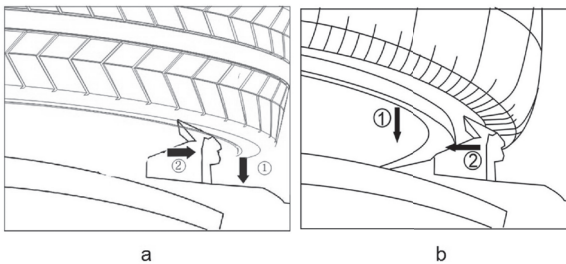

Fig.20

- Place the tire between the bead breaker shoe and rubber pad and keep the shoe between the bead and rim, about 1cm to the bead (Fig.17-a). Depress pedal C (Fig.17-b) to separate the tire from rim.
- Repeat the above steps on other part of the tire to get the tire separated thoroughly from the rim.

NOTE:

When using the bead breaking arm, do not put arms and hands between the tire and the bead breaker

- Press switch handle button N (Fig. 18), fix arm.
- Press pedal A, tilt the column.
- Place the wheel on the turntable. Depress pedal B, For the asymmetric deep groove rim, keep the narrow rim upward (Fig. 19) .
- NOTE : *Different types of clamping can be chosen in accordance with different rims.*
- In case of inward clamping, shrink the jaws together, place the wheel on the turntable and depress pedal B to clamp (Fig.20-a).
- In case of outward clamping, enlarge the jaws outward (2-3cm away from periphery of the rim) and place the wheel on the turntable. Press down the rise/fall control lever to keep the rim close to the jaws, and depress pedal B to clamp it(as fig.20-b) .

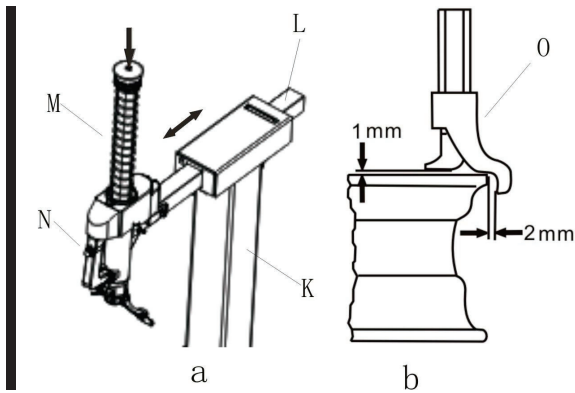

Fig.21

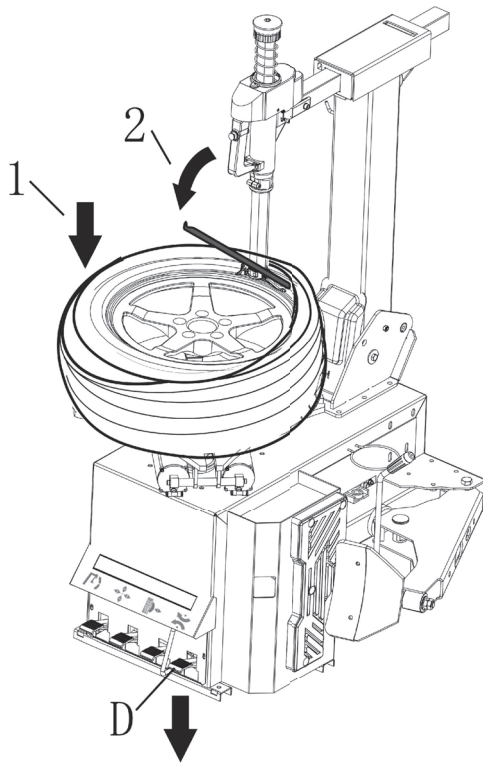

Fig.22

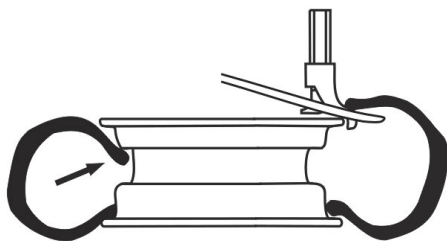

Fig.23

- Press pedal A (Fig.18), let column back to working position, pull back switch handle N (Fig. 21-a), let the arm L and hex column M move freely. Push N and press M, make mounting head O against rim (Fig. 21-b), press switch handle N lock arm and hex column. Make sure mounting head keep a distance of 1~2mm from upper edge of rim and 2mm from outer edge of rim to avoid mounting head scratch rim.
- Insert lever into wheel near mounting head (Fig. 22).
- Press lever as Fig. 22-2 and press wheel as fig. 22-1, until upper edge of wheel as Fig. 23, press lever slowly, until upper edge of wheel hang on the mounting head.

⚠ NOTE:

If inner tube, to avoid damage of inner tube, keep the position of air inlet valve and mounting head and lever as Fig. 24.

- Press pedal D (Fig. 22), turntable turn clockwise, until edge of wheel fall off.

⚠ NOTE:

- *For very tough and low profile wheel, wheel edge is easy to slip off, to avoid this, before turn clockwise of the turntable, may turn anti-clockwise a little to make the turntable back 1-2mm.*
- *If the demounting process is prevented, stop the turntable from turning around, lift pedal D (fig. 22), let the turntable turn anti-clockwise.*

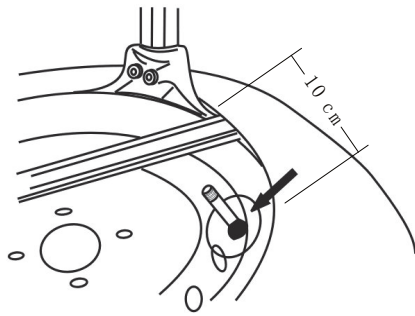

Fig.24

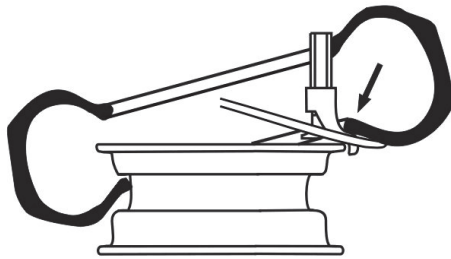

Fig.25

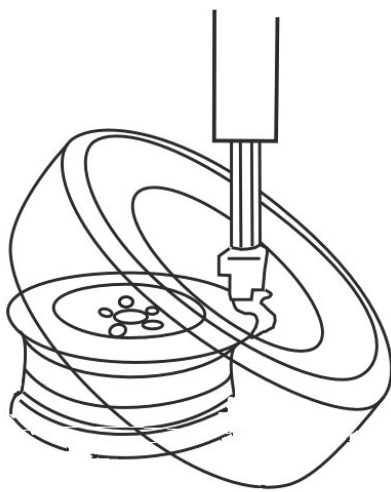

Fig.26

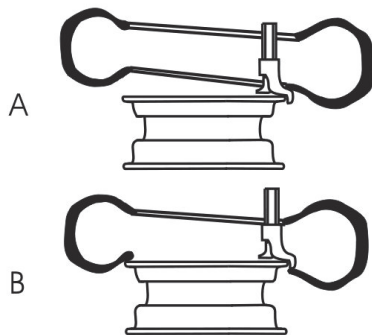

Fig.27

- If there is tube in the tire, remove it.
- Lift wheel, make the bottom edge of wheel as Fig. 25.
- Press pedal D until bottom edge of wheel fall off.
- Depress pedal A, tilt column, take off wheel, and finish demounting.

⚠ NOTE:

Keep hands and the rest of human body away from the moving parts of the machine. Never wear necklace, bracelet or loose clothes when operating the machine as it may cause danger!

4.3 Mounting Tire

⚠ NOTE:

Check the size of tire and rim to see if they match each other.

- Clamp the rim tightly in the same way as demounting tire.
- Use lubricant such as thick soap solution on the tire and the rim.
- Put the bead on the rim with the left side upward, press pedal A, make column back to working position (Fig.26) .
- Check the coordination of mount/demount head and rim. Readjust if necessary.
- Adjust relative position between the tire and the mount/demount head to make the tire bead cross the mount/demount head. At the end of the mount/demount head, the tire bead should be placed on the mount/demount head (Fig.27-A). At the beginning of the mount/demount head, the tire bead should be placed under the ball protuberance of the mount/demount head (Fig.27-B).
- Press down the central part of the tire. Depress the pedal D (Fig.22) to turn the turntable clockwise, making the lower tire bead fall into the rim groove completely (as fig.28-A).

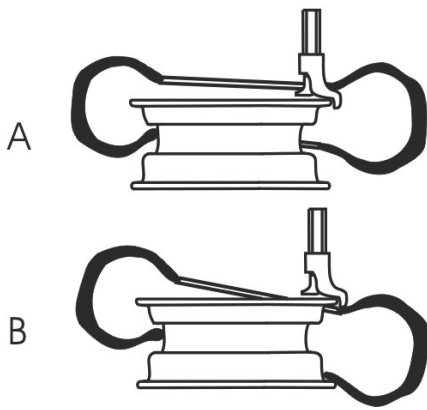

Fig.28

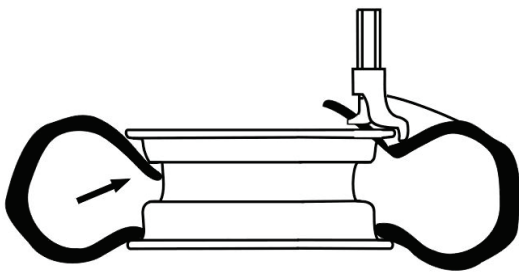

Fig.29

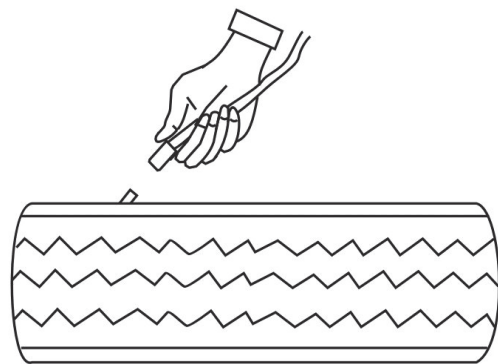

Fig.30

- If a tube needs to be installed in the tire, check first for the possible damages. Round it onto the rim. Make sure to keep the tube in the right position throughout the mounting process.
- To install the upper tire bead, place the tire well and readjust position of the tire bead (same as mount of the lower tire bead in Fig.28-B). Press down the tire opposite to the mount/demount head to the rim groove (Fig.29).
- Depress the pedal D (Fig.22) to turn the turntable while keeping pressing on the tire. When only 10~15cm is left, slow down to avoid damage of the tire bead. Stop the motor if there is any indication for damage. Lift the pedal D and turn the turntable counter-clockwise. Try again when the tire is back to the original shape.

➤ **⚠ NOTE:**

- *It is not necessary to move the handle of the screw every time if the size of rim matches the tire. Just move the swing arm.*
- *In the process of operation, turntable always goes clockwise, anti-clockwise is only for correcting wrong operation*

4.4 Inflating Tire

⚠ Danger! !

Inflating can be highly dangerous. Take precautions and pay close attention to the procedures. Check if the compressed air is well connected before inflating

Inflating procedures are shown in Fig.30. The machine is equipped with a gauge to read the pressure in the tire.

- Connect the outlet of the gun to the air inflation valve
- Slowly press the switch on the inflating gun for several times during inflation to make sure that the reading on pressure gauge meets the manufacturer's specifications. The pressure should not exceed 3.5 bar.
- If the pressure exceeds the limit, press the button on the gun inflator so that the pressure goes down to what is required.



Fig.31

⚠ Danger! Danger of explosion!

The safety procedures should be closely followed. Review and abide by the following instructions. Otherwise serious injury or death can be resulted. The manufacturer shall not be held responsible for any possible accident when the safety procedures are not followed

- *Carefully check the dimensions of rim and tire to see if they match each other. Check and make sure that the tire is not worn or damaged before inflation.*
- *When a high pressure is required, remove the tire from the tire changer and resume the inflation in a special protective hood.*
- *Be careful when inflating the tire. Keep hands and the rest of human body away from tire.*
- *The operator must adopt all the measures necessary in order to guarantee safe conditions.*

5. Trouble Shooting

Malfunction	Cause	Solution
The chuck does not rotate in any direction.	<ol style="list-style-type: none"> 1. Power plug not inserted. 2. Incorrect connection in the plug. 3. Electrical supply not suitable. 	Check correct plugging and its connection.(see cause 2 and 3)
Pressing the inverter pedal down causes the chuck to turn in an anti-clockwise direction.	Polarity inverted.	Invert the connections in the power plug
The chuck turns with insufficient power.	<ol style="list-style-type: none"> 1. Supply voltage wrong. 2. Driving belt loosen. 	<ol style="list-style-type: none"> 1. Check the correspondence between the supply voltage and that on the maker's plate. 2. Tighten the belt.
The bead breaker does not have sufficient power to break the tire bead.	<ol style="list-style-type: none"> 1. The pneumatic supply is not connected to the machine. 2. Insufficient pressure in the pneumatic system. 3. Pressure reducer is closed or badly adjusted (for versions with this device). 	<ol style="list-style-type: none"> 1. Connect the pneumatic supply. 2. Correct the supply pressure. 3. Open or correctly adjust the pressure reducer.

Other malfunctions should be checked and fixed by Professionally Qualified Personnel.

6. Maintenance



Note:

Only the specialized technician can do the maintenance. Before any maintenance is performed, disconnect the power and keep the plug within the sight of the maintenance personnel. and shut off compressed air, push the air valve switch to “Off” position and depress pedal 16 for 3 or 4 times to bleed the residual compressed air in the machine.

To keep the tire change in good condition and to prolong the work life, it is necessary to do regular maintenance according to the instructions on the user’s manual. Otherwise, the normal operation and reliability of the machine will be affected, or personal injury would be caused.

- Keep the machine and working area clean and prevent dust or foreign matter from entering the moving parts.
- Keep the quadrature column and the moving parts clean and lubricate (clean with diesel as in Fig.32-1 & 2 & 3).
- Keep the swing arm clean and lubricate it periodically so that it can move expectably.
- Weekly lubricate the faying surface between moving parts and rubbing surface with lithium lubricant.
- Check the oil level in the sprayer regularly. If the oil level does not reach the second line, fill L-HM46 (Fig. 33).
- Clear away the condensed material in the water separator around the sprayer regularly.
- Regularly check and adjust the tension of the belt.
- Check all connecting parts and bolts regularly and tighten them if necessary.
- Check and adjust locker handle periodically, to make sure after locking, mount head and rim keep 2-3m distance.

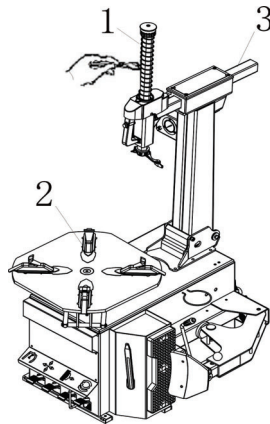

Fig.32

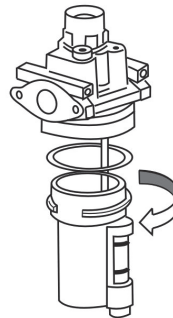

Fig.33

7. Storing and Scrapping

7.1 Storing

When the equipment needs to be stored for a long time:

- Disconnect the power and compressed air.
- Lubricate all the parts: slide block and groove.
- Empty all the oil/liquid cups.
- Cover the equipment with plastic shield.

7.2 Scrapping

When the equipment can no longer be used, disconnect the power and compressed air and dispose in accordance with the local regulations.

8. Spare parts list

This list is only for the reference of the maintenance personnel. The manufacturer will not be held responsible for any use other than the designed purpose.

In case any damage occurs, please contact your dealer or factory with the corresponding codes in the list..

SPARE PARTS LIST								
NO.	CODE	Description	Qty.		NO.	CODE	Description	Qty.
2065618 Parts of Column & Arm (Fig. 34)								
101	2065619	Column	1		138	6000387	Screw M10x30	1
102	3005009	Union IPL 4-01	1		139	3005190	Knob	1
103	6000120	Screw M6*30	4		140	2037701	Spring	1
104	2065640	Screw M10*25	2		141	2064803	Hex column	1
105	6000123	Screw M10	2		142	3005188	Washer	1
106	2065638	Locking plate	1		143	2052501	Washer $\phi 34 \times 10 \times 5$	1
107	6000126	Screw M12	2		144	6000184	Screw M10*25	1
108	2065640	Screw M12*60	2		145	3005275	Rubber block	1
109	2065639	Spring	2		146	2065643	Rubber block plate	1
110	2065641	Inflating gun hook	1		147	6000191	Screw M8*30	1
111	6000126	Screw M6	1		150	2065668	Tilting cylinder	1
112	2038801	Bearing	2		151	2039701	Tilting cylinder rear cover	1
113	2064379	Bearing pin	1		152	6000148	Screw M8	8
114	2065642	Roller seat	1		153	6000139	Washer $\Phi 8$	8
115	6000335	Screw M8*25	2		154	3005043	O-seal 82×2.6	2
116	6000127	Screw M8	2		155	2023701	Cylinder rod	4
117	6000139	Washer 8	2		156	2023501	Cylinder	1
118	6000103	Screw M8*16	2		157	6000242	Screw M12	1
119	6000424	Screw M12*55	1		158	6000135	Washer $\Phi 12$	1
120	6000144	Screw M12	1		159	2039801	Piston	1
121	3005274	Protective heel	2		160	3001001	Y-seal $20 \times 36 \times 8$	1
122	6000244	Screw M8*20	1		161	2039601	Tilting cylinder front cover	1
123	2065644	Washer	1		162	2065537	Piston rod	1
124	2065630	Arm	1		163	3005011	Union ISC8-01	2
125	3004201	Sleeve	1		170	2039201	Locking cylinder	2
126	2045101	Spring	2		171	2021201	Cylinder cover	1
127	2064804	Locking plate	1		172	3005191	O-seal ring	1
128	3005039	Cover	1		173	3004101	Locking cylinder body	1
129	6000138	Washer $\Phi 6$	1		180	2039001	Mount /demount head	
130	6000114	Screw M6*20	3		181	2039101	Mount /demount head	1
131	6000347	Screw M5*12	1		182	3004001	Washer	1
132	6000143	Screw M10	1		183	3004201	Mount/demount head protector	1
133	6000134	Washer 10	1		184	2004801	Roller pin	1
134	3005001	Union IPB 4-01	1		185	2004701	Roller	1

135	2021301	Locking valve	1		186	6000334	Screw M10×10	2
136	6000119	Screw M5*12	4		187	6000225	Screw M10×16	2
137	6000121	Screw M8x30	1					
2015801 Parts of Turning Table Assembly (Fig.35)								
201	2015901	Turn Table	1		220	2017801	Complete cylinder	2
202	6000129	Screw M16*40	1		221	2018001	Cylinder axis	1
203	2017101	Jaw	4		222	3005074	Union IPL6-01	1
204	2016201	Slide	4		223	2045801	Cylinder front cover	1
205	2038201	Slide plate	2		224	3004701	O-seal 68.3*3.5	2
206	2017201	Connecting rod	4		225	2018101	Cylinder rod	4
207	2053201	Connecting rod ring	4		226	3005157	Y-seal	1
208	6000329	Washer 12*24*2	4		227	2064398	Brushing	1
209	6000213	Washer 12	4		228	3005250	O-seal 75*5.7	2
210	6000189	Screw M12*85	4		229	3005249	O-seal 16*24	1
211	6000196	Retaining ring 70	1		230	2012001	Piston	1
212	2016801	Turn plate	1		231	6000144	Screw M12	1
213	2016601	Cylinder support	4		232	2017901	Cylinder	1
214	6000135	Washer 12*20*2	8		233	2045901	Cylinder rear cover	1
215	6000236	Retaining ring 12	8		234	3005075	Union IPB6-01	1
					235	6000308	Screw M5	8
2053301 Parts of Rotating Valve Assembly (Fig.36)								
300	2053301	Complete rotating valve	1		303	3004601	O-seal 59.5*3.1	3
301	2010901	Rotating valve core	1		304	2011001	Rotating valve casing	1
302	3005004	Union IPC6-01	4		305	6000356	Screw M3*5	4
2064938 Parts of Gearbox Assembly (Fig. 36)								
306	2064938	Complete gearbox	1		320	6000148	screw M8	5
307	3000801	Oil ruler	1		321	2064158	Oil seal cover	1
308	3000901	Oil ruler casing	1		322	3004501	O seal 35*3.1	1
309	6000121	Screw M8x30	5		323	6000168	Bearing 30205	2
310	2009201	Upper cover	1		324	2009601	Worm screw	1
311	6000166	Bearing 6010	1		325	6000337	Key 6*6*20	1
312	2009401	Gearbox shaft	1		326	3005127	Seal 25*40*8	1
313	6000102	Screw M8x20	1		327	6000170	Key12*8*50	1
314	6000199	Washer 8	1		328	6000112	Screw M6*12	1
315	2037201	Washer	1		329	6000101	A-key12*8*40	1
316	2009701	Pulley	1		330	6000204	Pin 8*16	1
317	2009501	Worm Gear	1		331	6000200	Washer 10*30*2	6
318	6000167	Bearing 6208	1		332	6000181	Screw M10*160	6
319	2009301	Worm Gear cover	1					
2012501 Parts of Motor Assembly (Fig.36)								
400	2012501	Motor	1		406	6000192	Screw M8x35	4
401	4003101	Motor 220V 1.2KW 50HZ (standard)	1		407	6000139	Washer 8x22x2	8
	4002801	Motor380V 0.75KW			408	6000134	Washer 10x20x2	3

		50HZ (optional)					
	4003201	Motor 110V 1.2KW 60HZ (optional)			409	6000336	Screw M10 4
402	2012701	Motor Pulley	1		410	3003601	Washer 6
403	6000130	Screw M6*10	2		411	6000199	WasherΦ8 4
404	6000237	Belt A660	1		412	6000127	Screw M8 4
405	2012601	Motor Support	1		413	4004444	Capacitor 1
2065595 Parts of Body Assembly (Fig. 37)							
501	2065596	Frame	1		516	6000348	Screw M6*10 1
502	2038701	Sign plate	1		517	6000187	Screw M10*55 6
503	3000101	Frame foot rubber	4		518	6000134	Washer 10*22*2 6
504	3005273	Robber buffer	1		519		Regulator base 1
505	6000253	Screw M6*16	5		520	4000701	Regulator 1
506	6000325	Washer 6*18*1.6	6		521	3005080	Union IPC 4-02 2
507	3005277	Robber buffer	1		522	2065615	Side cover 1
508	2045001	Hanger	1		523	6000325	Washer 6*16*2 4
509	2065612	Column base	1		524	6000198	Washer φ6 4
510	6000184	Screw M10*25	4		525	6000431	Screw M6*16 4
511	2037401	Washer φ38*10*4	4		526	3005006	Union IPC 8-02 1
512	2065540	Pin	2		527	4004387	F.R.L. 1
513	6000182	Screw M10*20	2		528	3005026	Union 1
514	6000123	Screw M10	2		529	3005010	Union IPL 8-02 1
515	3005272	Cover	1		530	4000901	Union 1
2064896 Pedal Assembly (Fig. 38)							
531	2065616	Pedal	1		556	2039301	Switch plate base 1
532	6000139	Washer 8*22*2	3		557	6000277	Screw M5*20 2
533	6000295	Screw M8*20	3		558	3005280	Switch handle 1
534	6000148	Screw M8	2		559	6000268	Screw M4*16 1
535	2065617	Pedal base	1		560	2065754	Connecting rod 1
536	6000325	Washer 6*12*2	2		561	6000244	Screw M8*20 1
537	6000348	Screw M6*10	2		562	6000349	Screw M3*8 2
540	2065752	Pedal 1	1		563	6000134	Washer Φ10*22*2 1
541	2065750	Pedal 2	2		564	6000369	Pin Φ4*25 1
542	2065751	Pedal 3	1		565	2065748	Pedal support 1
543	2065758	Pedal spring	3		566	2065757	V-Spring 1
544	6000148	Screw M8	4		567	2065749	Pedal axis 1
545	6000139	Washer Φ8	4		568	6000236	Ring Φ12 2
546	3005279	Rod	2		570	6000241	Pin Φ4*30 3
547	6000325	Washer Φ6	12		571	2065850	Five way valve rod 3
548	6000114	Screw M6*20	12		572	3005289	Five way valve cover 3
549	3005066	Union IPL8-01	1		573	3005290	Five way valve spacer 15
550	3005278	Sliding union	1		574	3005213	O seal 18
551	2065756	Sliding union cover	1		575	3005288	Five way valve body 3
552	6000375	Screw M3*10	2		576	3005005	Union IPC8-01 4
553	3005031	Switch cover	1			3005004	Union IPC6-01(for clinder) 2

554	4000502	Switch	1		577	3005212	Silencer	6
555	2064399	Switch plate	1		578	3005067	Union IPB8-01	2
2065790 Parts of Bead Breaker Cylinder (Fig. 39)								
600	2065792	Complete bead breaker cylinder	1		609	3004401	O seal 185*5.7	1
601	2011201	cylinder	1		610	2011301	Cylinder cover	1
602	3005066	UnionIPL8-01	1		611	2011601	Screw	2
603	6000114	Screw M6*20	12		612	3005027	Union	1
604	3005029	Y-seal 170*185*11	2		613	3003401	Y-seal 20*30*7	1
605	3005028	Ring	1		614	6000140	Washer 22*29*0.5	1
606	2011401	Piston	1		615	6000178	Retainer Ring Φ30	1
607	3004301	O seal 20*2.4	1		616	3005010	Union IPL8-02	1
608	2011501	Piston rod	1		617	6000233	Screw M6	12
2065645 Breaker Arm Assembly (Fig. 39)								
631	2038401	Spring	1		636	3000701	Handle cover	1
632	6000136	Washer 16*30*2	3		637	2065654	Pin	1
633	6000318	Screw M16	3		638	3005134	Shovel cover	1
634	2065646	Arm	1		639	2065654	Pin	1
635	2065652	Shovel l	1		640	2064378	Screw M16*110	1
1002154 Quick inflating system-optional(Fig 40)								
701	4004001	Safety valve	1		709	2064825	Inflatable tube	1
702	3005090	Copper connection	1		710	3005193	Valve sleeve	1
703	3005006	Union IPC8-02	1		711	3005192	O seal Φ32.5*3.55	2
704	4004348	One-way valve	1		712	2064827	Spring 1.8*37.5*23.4*3	1
705	3005036	Copper T-way union	1		713	6000388	Retainer ring Φ32	1
706	2064826	Air tank	1		714	2064828	Valve	1
707	3005202	Elbow G1"-G1"	1		715	2064826	Explosive filling mouth	1
708	3005204	Ring bush G1"-G3/4"	1					

9. Exploded drawings

9.1 Column assembly

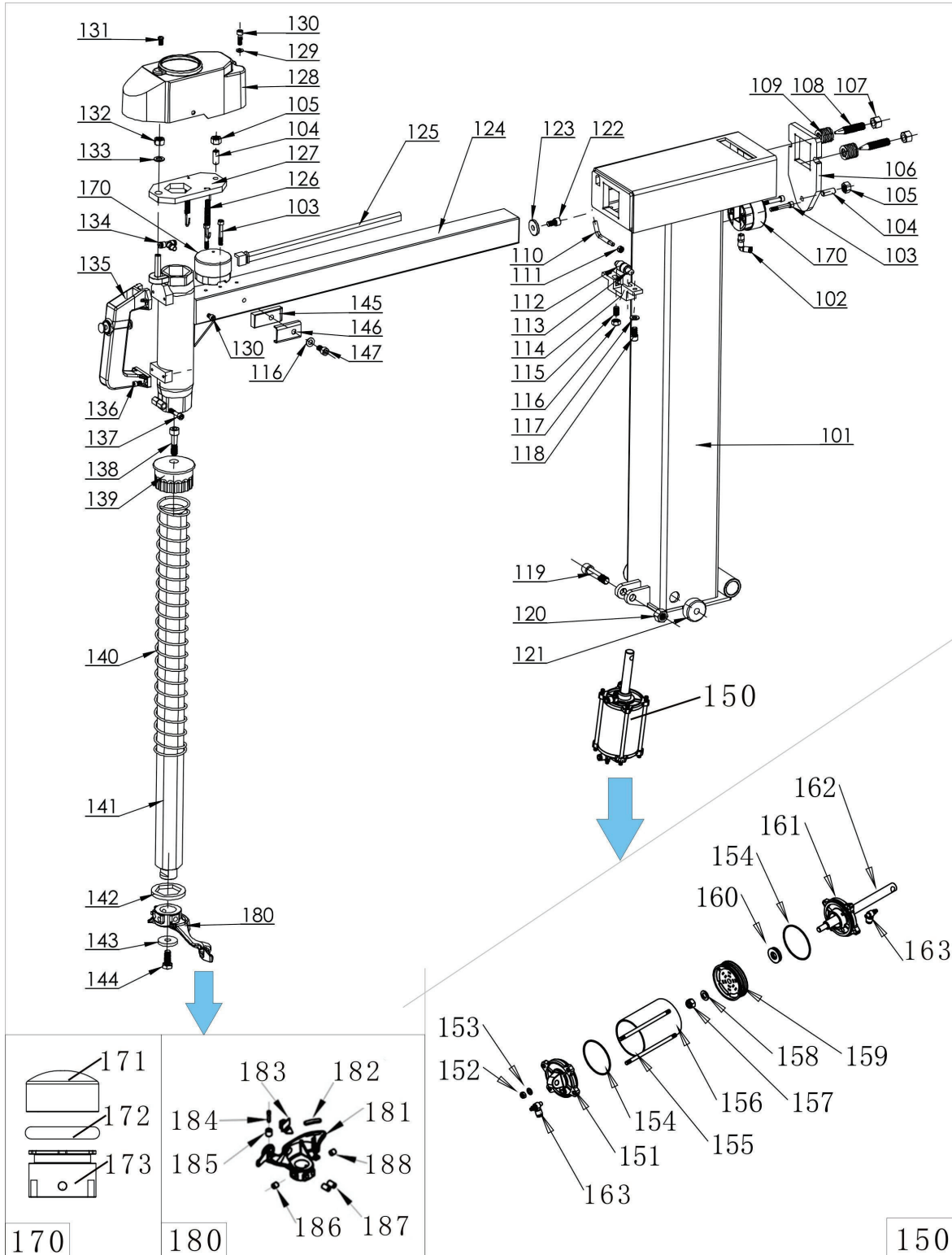

Fig.34

9.2 Turntable assembly

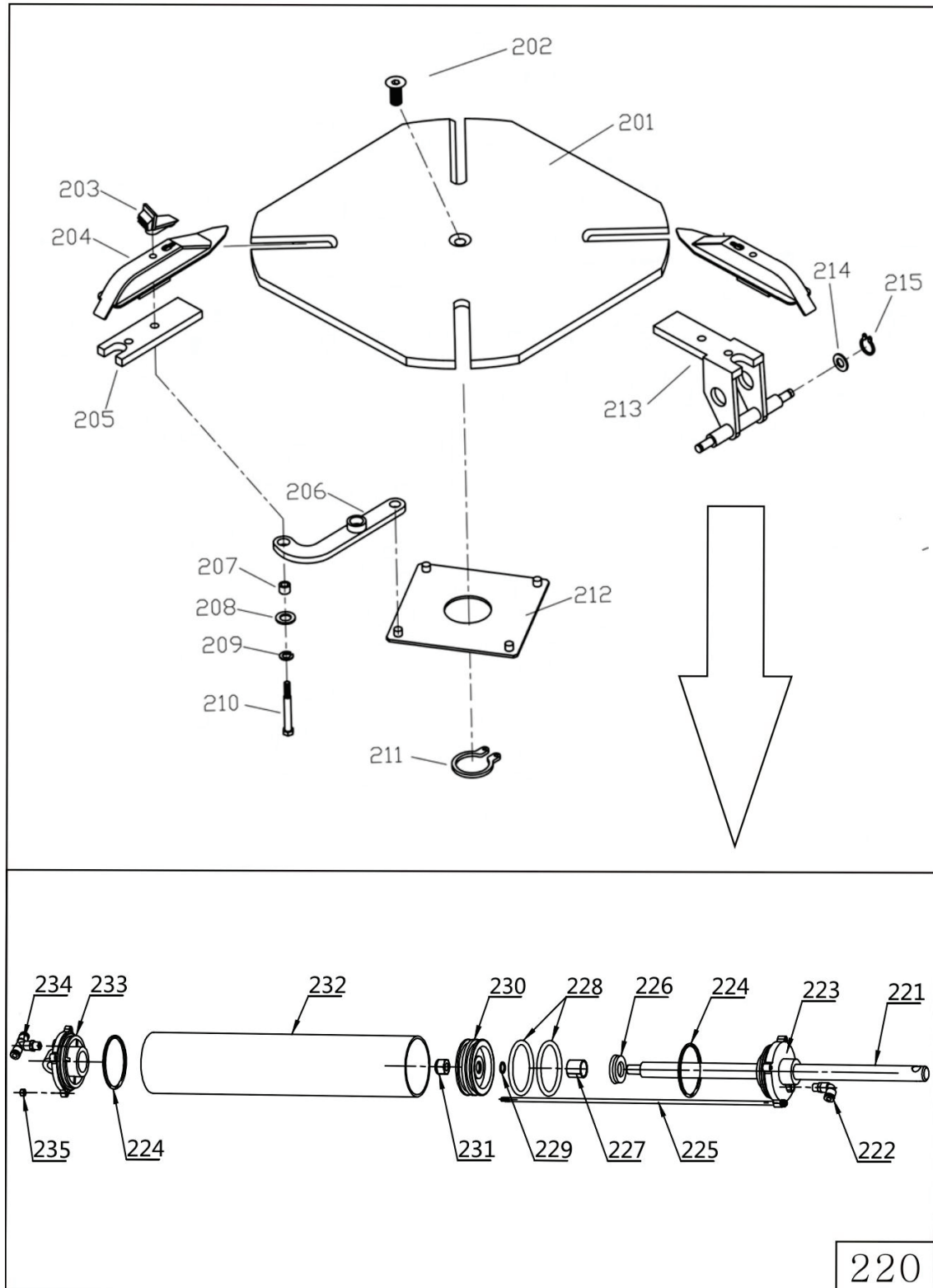

Fig.35

9.3 Gearbox & motor assembly

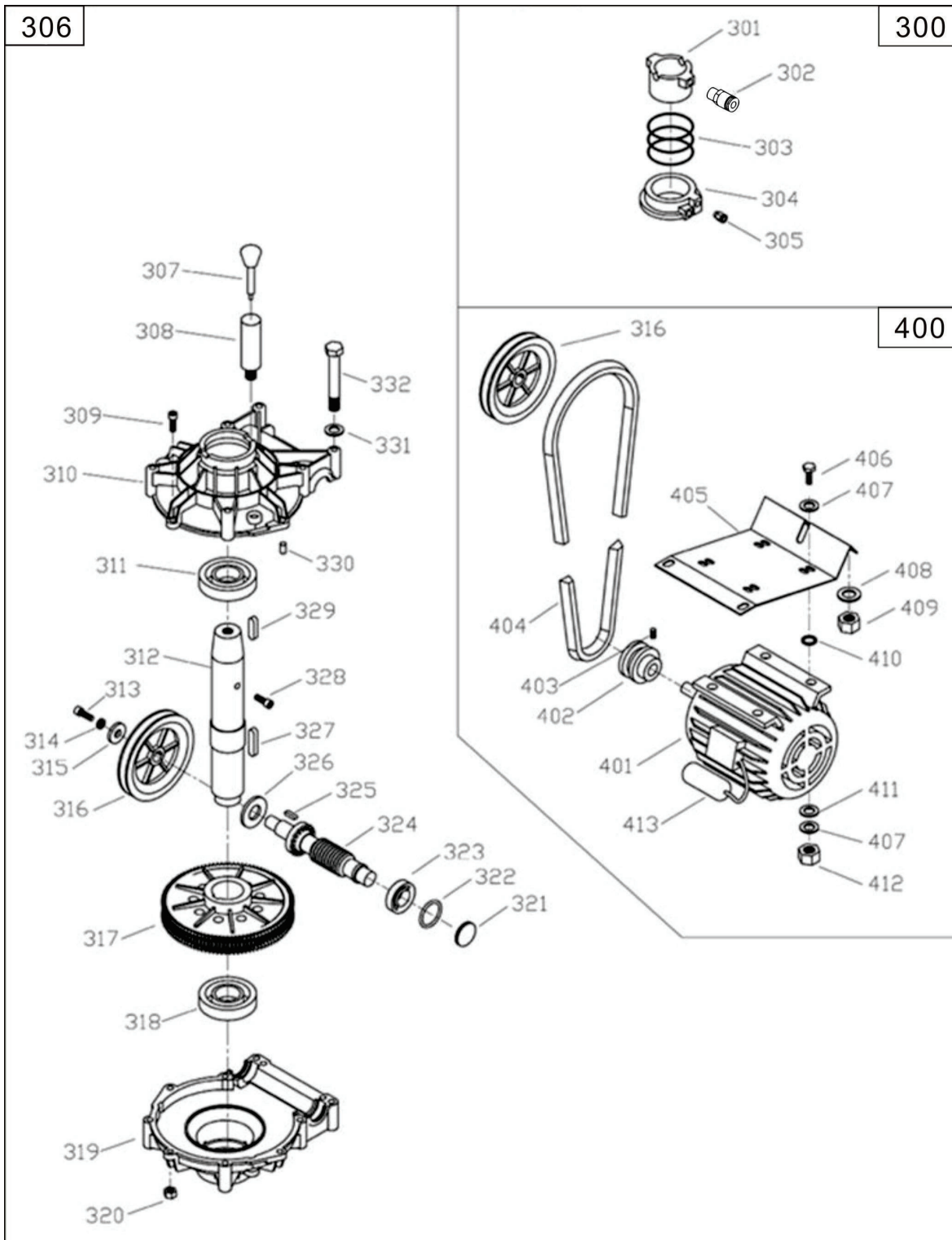

Fig.36

9.4 Body assembly

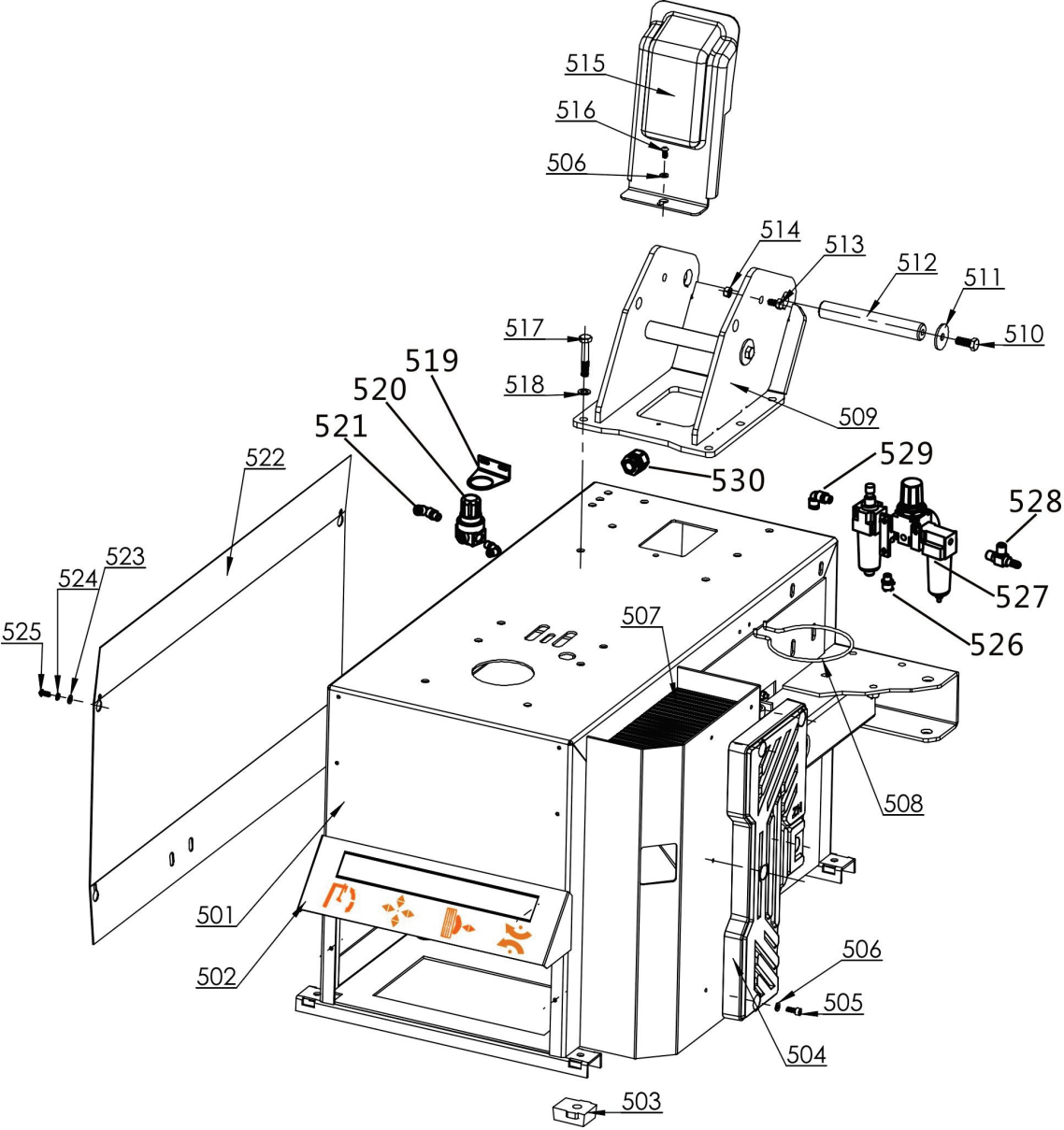

Fig.37

9.5 Pedal Assembly

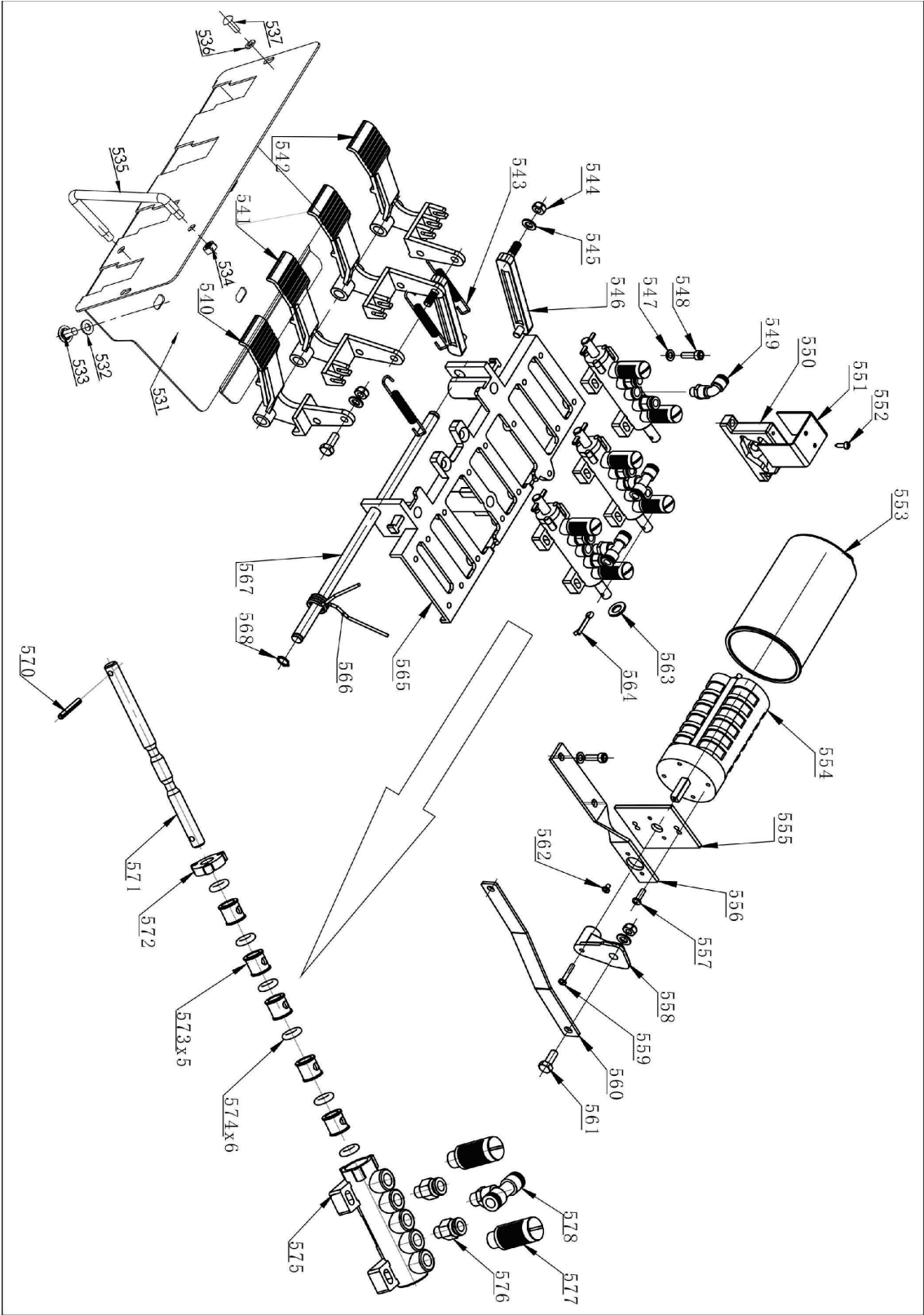

Fig.38

9.6 Bead Breaker Cylinder & Breaker Arm Assembly

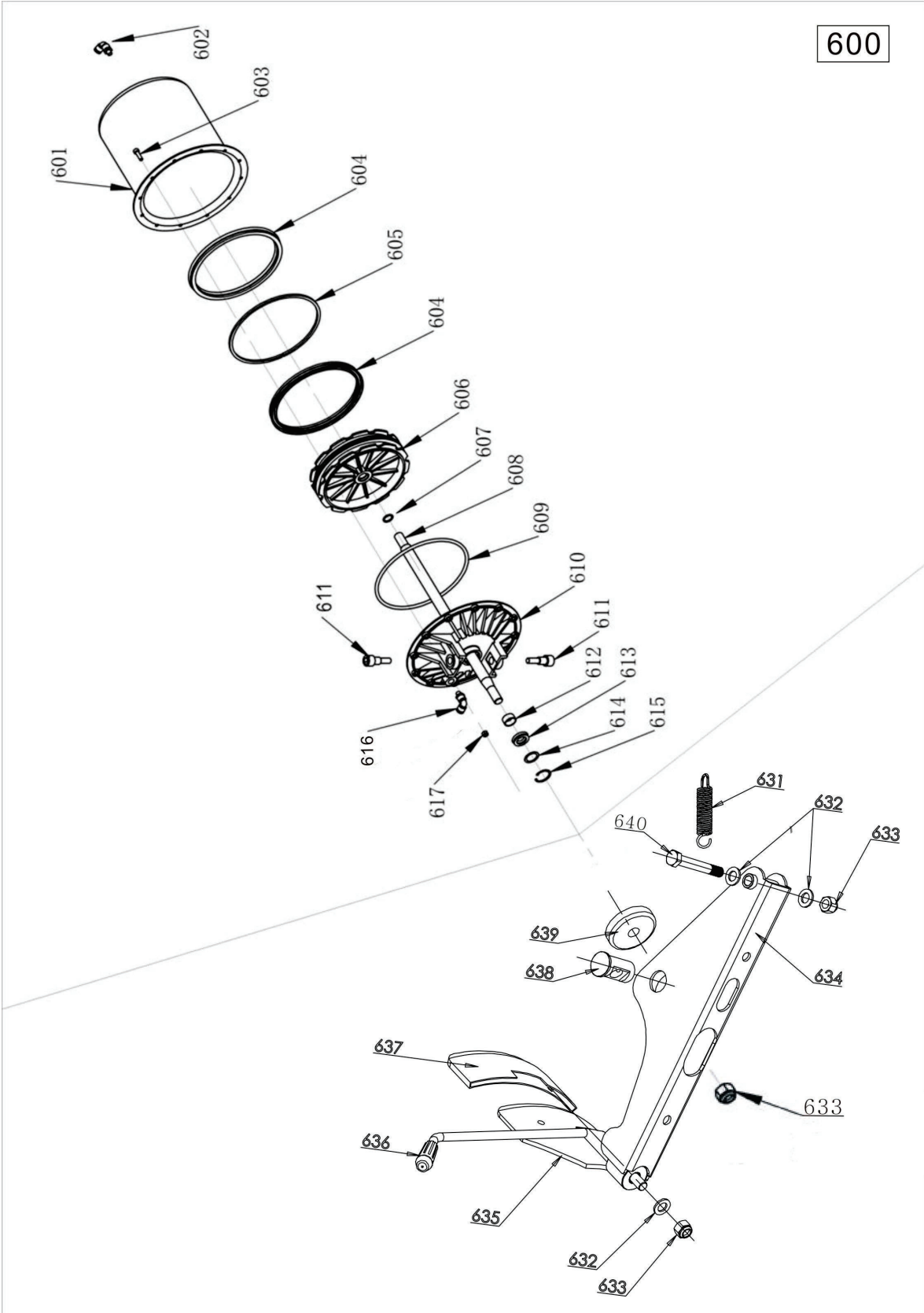

Fig.39

9.7 Quick inflating system(Optional)

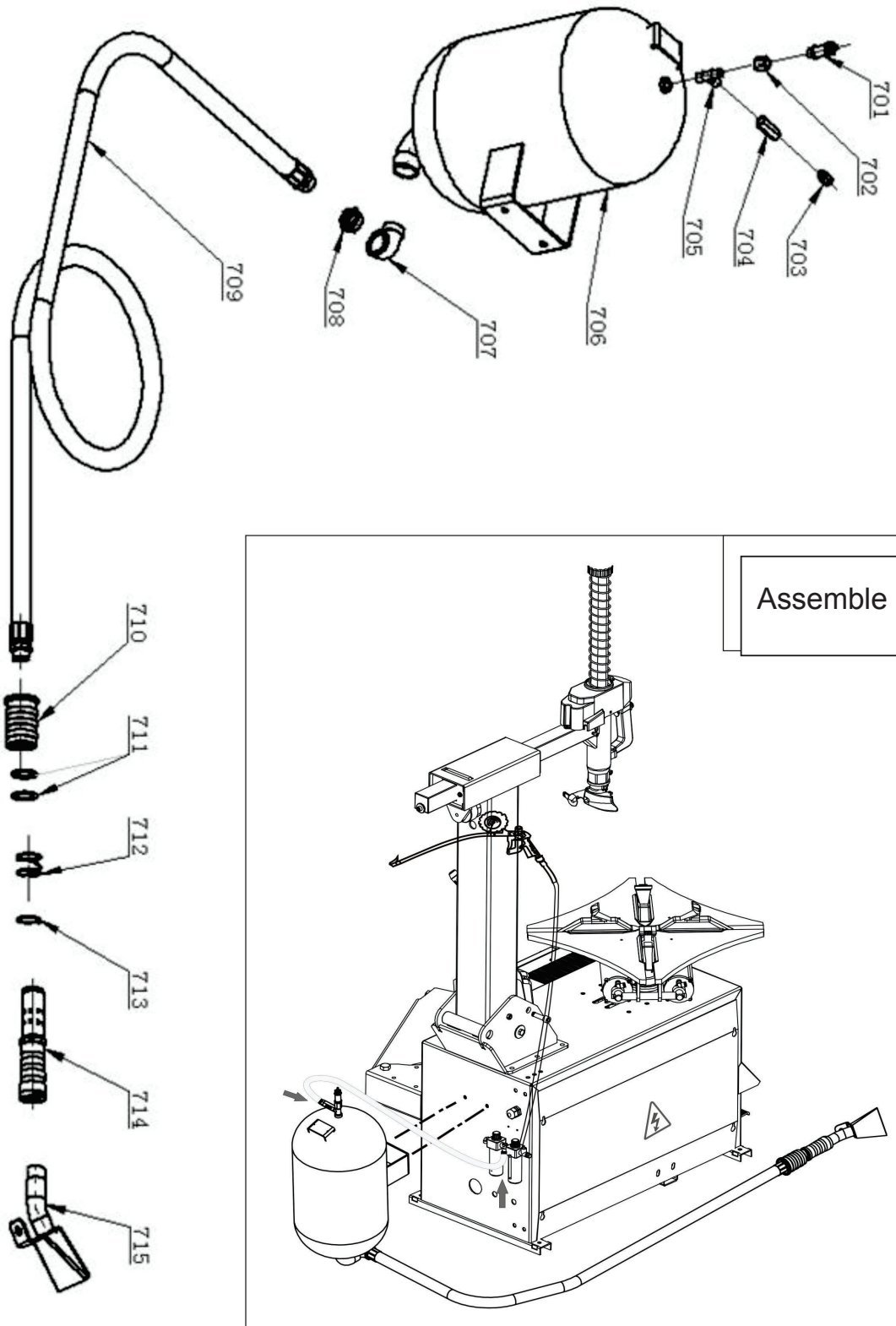

Fig.40

Appendix 1

Electrical Diagram

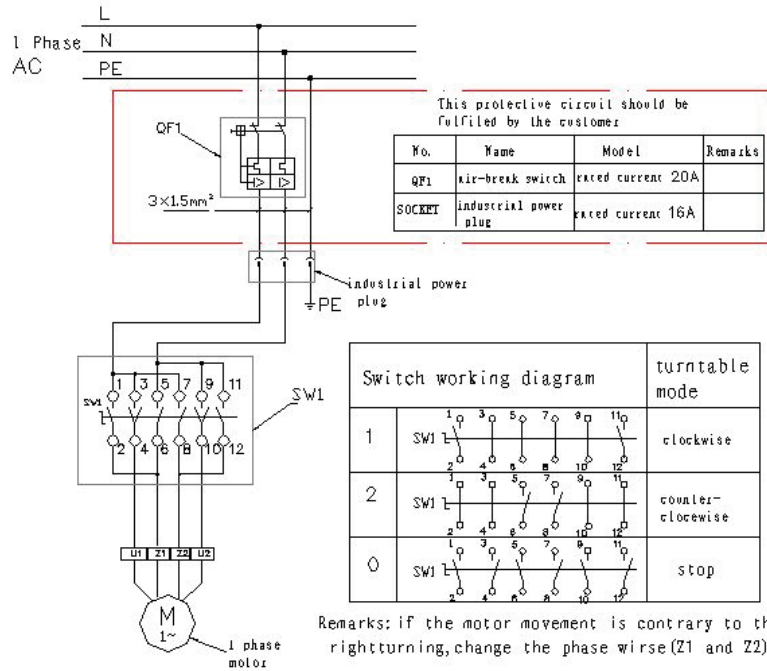

Fig.41

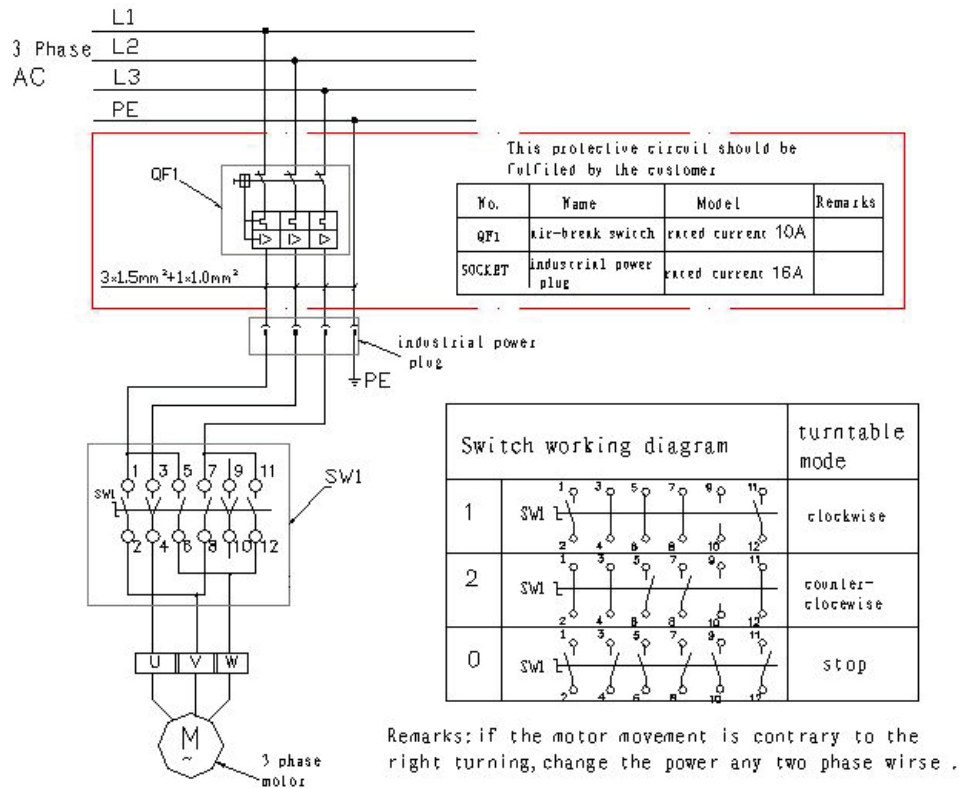

Fig.42

Appendix 2

Air Passage Diagram

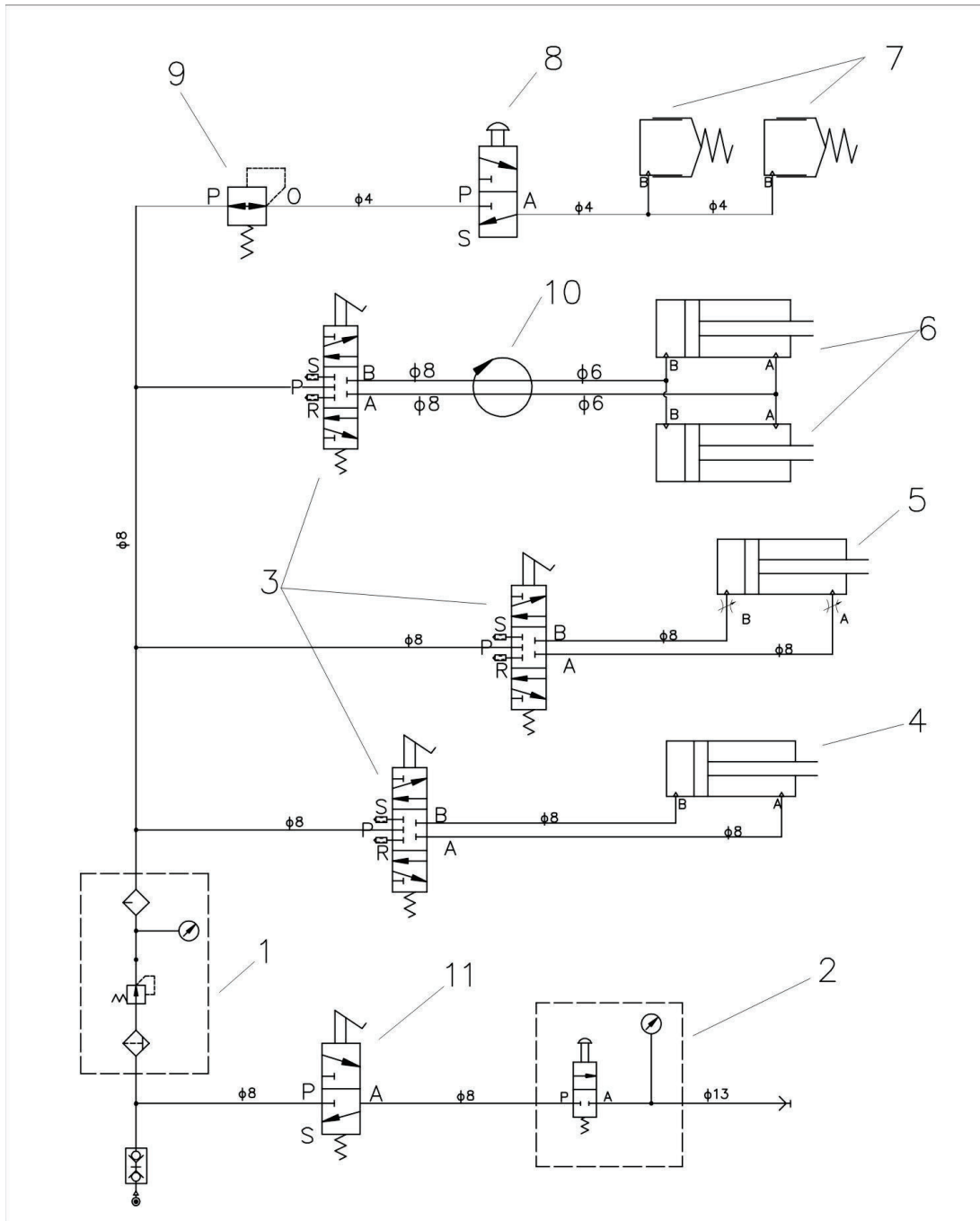

Fig.43

- | | | |
|--------------------------|----------------------|-----------------------------|
| 1. Filter unit FR+L | 5. Tilting cylinder | 9. Pressure valve |
| 2. Inflation gun | 6. Clamping cylinder | 10. Rotating valve assembly |
| 3. Five-way valve | 7. Locking cylinder | 11. Foot valve |
| 4. Bead breaker cylinder | 8. Locking switch | |

Appendix 3

Drawing of installation for small package

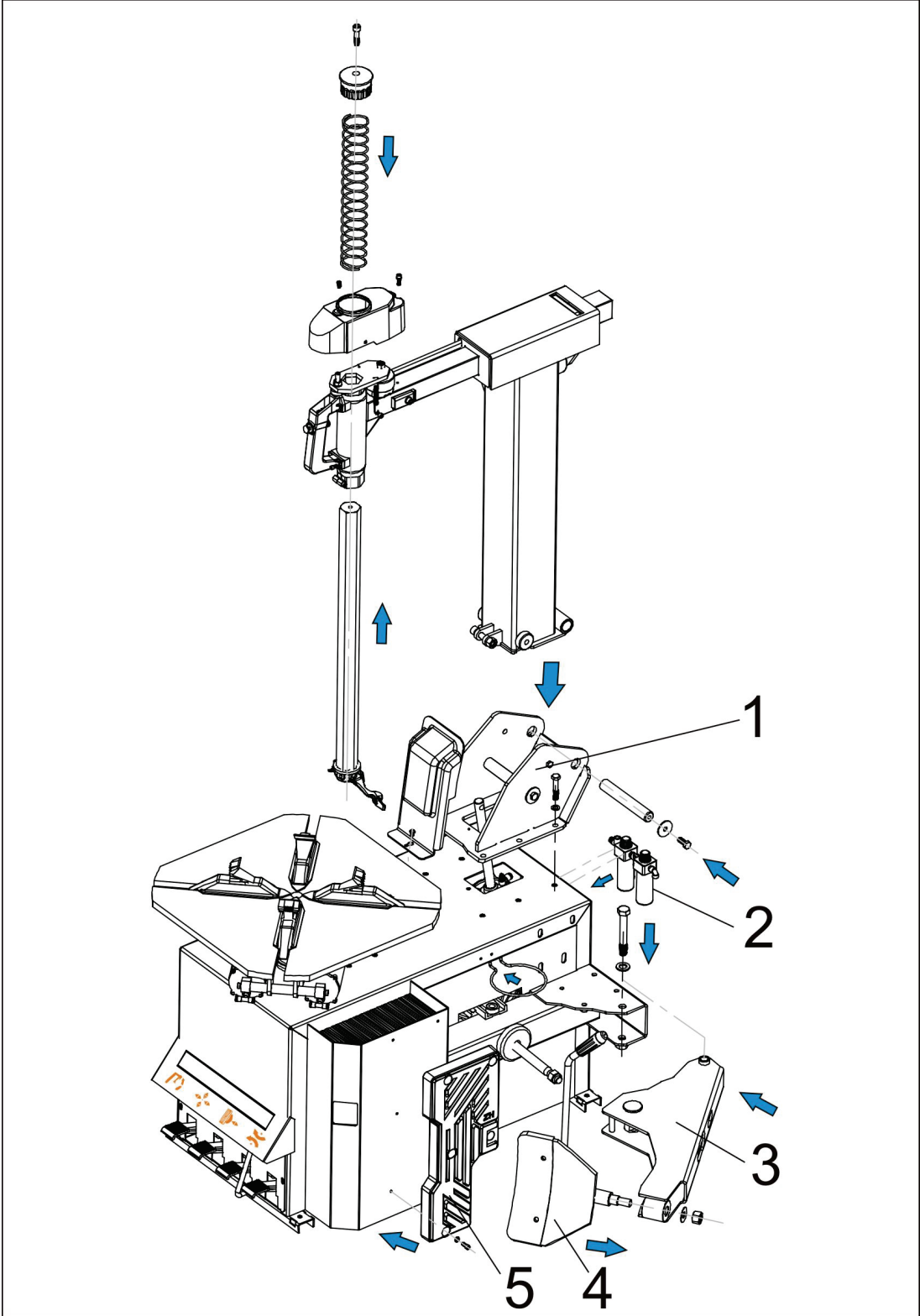

Fig.44

